

Technical Reference



RSA6100A Series Real-Time Spectrum Analyzer Specifications and Performance Verification 071-1915-03

Warning

The servicing instructions are for use by qualified personnel only. To avoid personal injury, do not perform any servicing unless you are qualified to do so. Refer to all safety summaries prior to performing service.

www.tektronix.com

Copyright © Tektronix. All rights reserved. Licensed software products are owned by Tektronix or its subsidiaries or suppliers, and are protected by national copyright laws and international treaty provisions.

Tektronix products are covered by U.S. and foreign patents, issued and pending. Information in this publication supercedes that in all previously published material. Specifications and price change privileges reserved.

TEKTRONIX and TEK are registered trademarks of Tektronix, Inc.

Contacting Tektronix

Tektronix, Inc.
14200 SW Karl Braun Drive
P.O. Box 500
Beaverton, OR 97077
USA

For product information, sales, service, and technical support:

- In North America, call 1-800-833-9200.
- Worldwide, visit www.tektronix.com to find contacts in your area.

Warranty 2

Tektronix warrants that this product will be free from defects in materials and workmanship for a period of one (1) year from the date of shipment. If any such product proves defective during this warranty period, Tektronix, at its option, either will repair the defective product without charge for parts and labor, or will provide a replacement in exchange for the defective product. Parts, modules and replacement products used by Tektronix for warranty work may be new or reconditioned to like new performance. All replaced parts, modules and products become the property of Tektronix.

In order to obtain service under this warranty, Customer must notify Tektronix of the defect before the expiration of the warranty period and make suitable arrangements for the performance of service. Customer shall be responsible for packaging and shipping the defective product to the service center designated by Tektronix, with shipping charges prepaid. Tektronix shall pay for the return of the product to Customer if the shipment is to a location within the country in which the Tektronix service center is located. Customer shall be responsible for paying all shipping charges, duties, taxes, and any other charges for products returned to any other locations.

This warranty shall not apply to any defect, failure or damage caused by improper use or improper or inadequate maintenance and care. Tektronix shall not be obligated to furnish service under this warranty a) to repair damage resulting from attempts by personnel other than Tektronix representatives to install, repair or service the product; b) to repair damage resulting from improper use or connection to incompatible equipment; c) to repair any damage or malfunction caused by the use of non-Tektronix supplies; or d) to service a product that has been modified or integrated with other products when the effect of such modification or integration increases the time or difficulty of servicing the product.

THIS WARRANTY IS GIVEN BY TEKTRONIX WITH RESPECT TO THE PRODUCT IN LIEU OF ANY OTHER WARRANTIES, EXPRESS OR IMPLIED. TEKTRONIX AND ITS VENDORS DISCLAIM ANY IMPLIED WARRANTIES OF MERCHANTABILITY OR FITNESS FOR A PARTICULAR PURPOSE. TEKTRONIX' RESPONSIBILITY TO REPAIR OR REPLACE DEFECTIVE PRODUCTS IS THE SOLE AND EXCLUSIVE REMEDY PROVIDED TO THE CUSTOMER FOR BREACH OF THIS WARRANTY. TEKTRONIX AND ITS VENDORS WILL NOT BE LIABLE FOR ANY INDIRECT, SPECIAL, INCIDENTAL, OR CONSEQUENTIAL DAMAGES IRRESPECTIVE OF WHETHER TEKTRONIX OR THE VENDOR HAS ADVANCE NOTICE OF THE POSSIBILITY OF SUCH DAMAGES.

Table of Contents

General Safety Summary	v
Related Manuals	vii

Specifications

Specifications	1-1
Performance Conditions	1-1
Electrical Specifications	1-2
Electrical Functional Specifications	1-19
Physical Characteristics	1-24
Safety	1-26
Certifications and Compliances	1-27
Environmental Characteristics	1-28
Digital IQ Output Connector Pin Assignment (Option 05 Only)	1-30
Digital IQ Output Timing	1-33

Performance Verification

Performance Verification	2-1
Prerequisites	2-1
Required Equipment	2-2
Preliminary Checks	2-3
Warranted Characteristics tests	2-5
Frequency Accuracy	2-5
Phase Noise	2-9
RF Input	2-12
Amplitude	2-13
Noise and Distortion	2-23
IF Flatness (Channel Response)	2-26
Spurious Response	2-30
Test Record	2-35
RSA6100A Series Test Record	2-36

List of Figures

Figure 1-1: Digital IQ output connector pin assignment	1-30
Figure 1-2: IQ Timing	1-35
Figure 2-1: Connections for Reference Frequency Output Accuracy check	2-5
Figure 2-2: Power meter setup	2-6
Figure 2-3: Power meter calibration	2-6
Figure 2-4: Equipment connections for Ref Out power level check	2-7
Figure 2-5: Equipment connections for Ref In power level check ..	2-7
Figure 2-6: Error message showing loss of lock to External Reference signal	2-8
Figure 2-7: Equipment connections for phase noise checks	2-9
Figure 2-8: Equipment connections for VSWR check	2-12
Figure 2-9: Equipment connections for RF Flatness check	2-14
Figure 2-10: Equipment connections for Third Order Intermodulation Distortion check	2-23
Figure 2-11: Equipment connections for IF Flatness check	2-27
Figure 2-12: Equipment connections for Image Suppression check	2-32
Figure 2-13: Equipment connections for Signal Spurious check ...	2-33

List of Tables

Table 1-1: Frequency	1-2
Table 1-2: Phase noise	1-3
Table 1-3: RF input	1-4
Table 1-4: Maximum input level	1-4
Table 1-5: Input attenuator	1-4
Table 1-6: Amplitude and RF flatness (excluding mismatch error)	1-5
Table 1-7: Noise and distortion	1-6
Table 1-8: Channel response	1-7
Table 1-9: Channel response (center frequency 33.0 GHz)	1-8
Table 1-10: Channel response (3.0 GHz < center frequency < 6.2 GHz)	1-9
Table 1-11: Channel response (6.2 GHz < center frequency < 14 GHz, RSA6114A only)	1-9
Table 1-12: Pulse measurements, typical	1-10
Table 1-13: Spurious response	1-11
Table 1-14: Spurious response with signal	1-11
Table 1-15: Acquisition	1-11
Table 1-16: Amplitude vs. time	1-13
Table 1-17: Trigger	1-13
Table 1-18: Decimated clock period	1-15
Table 1-19: Resolution bandwidth filter (SA mode)	1-15
Table 1-20: Range and settable RBW (SA mode)	1-16
Table 1-21: Resolution bandwidth filter (time-domain mode)	1-16
Table 1-22: Range and settable RBW (time-domain mode)	1-17
Table 1-23: Preamp (Option 01)	1-17
Table 1-24: IF output (Option 05)	1-18
Table 1-25: Digital IQ output1	1-18
Table 1-26: 28 Volt noise source drive output	1-18
Table 1-27: Measurement function	1-19
Table 1-28: Views by domain	1-20
Table 1-29: Analog demodulation accuracy	1-20
Table 1-30: Frequency and phase error referenced to non-chirped signal	1-21
Table 1-31: Frequency and phase error referenced to a linear chirp	1-21
Table 1-32: General purpose digital modulation analysis (Option 21)	1-21

Table 1-33: Digital demodulation accuracy (Option 21)	1-22
Table 1-34: ACLR measurement	1-23
Table 1-35: Digital phosphor spectrum processing (DPx)	1-23
Table 1-36: Physical characteristics	1-24
Table 1-37: Display/computer	1-25
Table 1-38: Environmental characteristics	1-28
Table 1-39: Power Requirements	1-29
Table 1-40: I OUTPUT connector pin assignment	1-30
Table 1-41: Q OUTPUT connector pin assignment	1-32
Table 1-42: Mating connections	1-33
Table 1-43: EXT_IQ_DAV Duty cycle versus Span	1-34
Table 1-44: IQ Timing	1-35
Table 2-1: Equipment required for Performance Verification	2-2
Table 2-2: Phase Noise Offsets (Low Range)	2-10
Table 2-3: Phase Noise Offsets (High Range)	2-11
Table 2-4: RF Flatness (Preamp OFF, if installed)	2-15
Table 2-5: RF Flatness (Option 01 Preamp ON)	2-20
Table 2-6: Frequencies of interest for DANL check	2-25
Table 2-7: Frequencies of interest for DANL check (Option 01) ...	2-26
Table 2-8: IF Flatness	2-28
Table 2-9: Residual Response Center Frequencies	2-30
Table 2-10: Image Suppression Settings	2-32
Table 2-11: Center Frequencies for Half-IF	2-34

General Safety Summary

Review the following safety precautions to avoid injury and prevent damage to this product or any products connected to it.

To avoid potential hazards, use this product only as specified.

Only qualified personnel should perform service procedures.

While using this product, you may need to access other parts of a larger system. Read the safety sections of the other component manuals for warnings and cautions related to operating the system.

To Avoid Fire or Personal Injury

Use Proper Power Cord. Use only the power cord specified for this product and certified for the country of use.

Ground the Product. This product is grounded through the grounding conductor of the power cord. To avoid electric shock, the grounding conductor must be connected to earth ground. Before making connections to the input or output terminals of the product, ensure that the product is properly grounded.

Observe All Terminal Ratings. To avoid fire or shock hazard, observe all ratings and markings on the product. Consult the product manual for further ratings information before making connections to the product.

The inputs are not rated for connection to mains or Category II, III, or IV circuits.

Power Disconnect. The power cord disconnects the product from the power source. Do not block the power cord; it must remain accessible to the user at all times.

Do Not Operate Without Covers. Do not operate this product with covers or panels removed.

Do Not Operate With Suspected Failures. If you suspect there is damage to this product, have it inspected by qualified service personnel.

Avoid Exposed Circuitry. Do not touch exposed connections and components when power is present.

Replace Batteries Properly. Replace batteries only with the specified type and rating.

Use Proper Fuse. Use only the fuse type and rating specified for this product.

Do Not Operate in Wet/Damp Conditions.

Do Not Operate in an Explosive Atmosphere.

Keep Product Surfaces Clean and Dry.

Provide Proper Ventilation. Refer to the manual's installation instructions for details on installing the product so it has proper ventilation.

Terms in this Manual

These terms may appear in this manual:



WARNING. *Warning statements identify conditions or practices that could result in injury or loss of life.*



CAUTION. *Caution statements identify conditions or practices that could result in damage to this product or other property.*

Symbols and Terms on the Product

These terms may appear on the product:

- DANGER indicates an injury hazard immediately accessible as you read the marking.
- WARNING indicates an injury hazard not immediately accessible as you read the marking.
- CAUTION indicates a hazard to property including the product.

The following symbol(s) may appear on the product:



Preface

This document contains the Specifications and the Performance Verification for the RSA6100A Series Real Time Spectrum Analyzers. It contains procedures suitable for determining that the analyzer functions, is adjusted properly, and meets the performance characteristics as warranted.

Related Manuals

The following documents relate to the operation or service of the analyzer:

- The *RSA6100A Series Quick Start User Manual* describes how to use your analyzer.
- The *RSA6100A Series Programmers Manual* describes how to use a computer to control the analyzer through the GPIB interface.
- The *RSA6100A Series Service Manual* provides information for maintaining and servicing your analyzer to the module level.



Specifications

Specifications

This section lists the RSA6100A Series Real Time-Spectrum Analyzer specifications. Items listed in the Performance Requirement column are generally quantitative, and are either tested by the *Performance Verification* procedure or are guaranteed by design. Items listed in the Reference Information column are useful operating parameters that have typical values; information in this column is not guaranteed.

NOTE. *In these tables, characteristics which are warranted are indicated by a ✓ symbol in the Characteristics column.*

Performance Conditions

The performance limits in these specifications are valid with these conditions:

- The spectrum analyzer must have been calibrated and adjusted at an ambient temperature between +20 °C and +30 °C.
- The spectrum analyzer must be in an environment with temperature, altitude, humidity, and vibration within the operating limits described in these specifications.
- The spectrum analyzer must have had a warm-up period of at least 20 minutes after starting the RSA6100A application.

Electrical Specifications

Table 1-1: Frequency

Characteristic	Description
Measurement frequency	
Frequency range, nominal	
RSA6106A	9 kHz to 6.2 GHz
RSA6114A	9 kHz to 14 GHz
Frequency Marker	
Readout Accuracy	$\pm(RE \times MF + 0.001 \times \text{Span} + 2)$ Hz RE: Reference Frequency Error MF: Marker Frequency [Hz]
Readout Resolution	Reference level dependent As small as 0.0001 μ V
Residual FM, typical	<2 Hz _{p-p} in 1 second at 200 MHz CF, 100 Hz span, Freq vs Time mode, Autoscale (95% confidence)
Span Accuracy	$\pm 0.3\%$ of span (Auto mode)
Reference Frequency (Standard and Option 10)	
Stability, nominal	2×10^{-8}
Adjustment Range	$\pm 5.5 \times 10^{-7}$
✓ Initial Accuracy at Cal	Within 1×10^{-7} (after a 10 min warmup)
Aging	
Per day	$\pm 1 \times 10^{-9}$ (after 30 days of operation)
Long term	$\pm 2 \times 10^{-7}$ (10 years)
Cumulative Error, typical (Temperature + Aging)	$\pm 2.5 \times 10^{-7}$ (10 years)
Temperature drift	$\pm 2 \times 10^{-8}$ (0 °C to 50 °C)
Reference output Level	
✓ Internal Reference selected	>0 dBm
External Reference selected, nominal	Approximately 0 dB gain from Reference input (+15 dBm Max output)
External Reference Input, nominal	BNC Connector, 50 Ω
External Reference Input Frequency, nominal	Every 1 MHz from 1 MHz to 25 MHz plus 1.2288 MHz, 4.8 MHz, & 19.6608 MHz. Spurious level on input signal must be <-80 dBc within 100 kHz offset to avoid on-screen spurious
External Reference Input Range	$\pm 3 \times 10^{-7}$
✓ External Reference Input Level	-10 dBm to +6 dBm

Table 1-2: Phase noise

Characteristic	Description	
✓ Specified	Noise sideband	Offset
Frequency = 1000 MHz	-80 dBc/Hz -100 dBc/Hz -106 dBc/Hz -107 dBc/Hz -128 dBc/Hz -134 dBc/Hz -134 dBc/Hz	100 Hz 1 kHz 10 kHz 100 kHz 1 MHz 6 MHz 10 MHz
Typical		
Frequency = 1000 MHz	-86 dBc/Hz -106 dBc/Hz -110 dBc/Hz -113 dBc/Hz -134 dBc/Hz -142 dBc/Hz -142 dBc/Hz	100 Hz 1 kHz 10 kHz 100 kHz 1 MHz 6 MHz 10 MHz
Frequency = 2000 MHz	-80 dBc/Hz -106 dBc/Hz -110 dBc/Hz -111 dBc/Hz -133 dBc/Hz -142 dBc/Hz -142 dBc/Hz	100 Hz 1 kHz 10 kHz 100 kHz 1 MHz 6 MHz 10 MHz
Frequency = 6000 MHz	-70 dBc/Hz -96 dBc/Hz -107 dBc/Hz -107 dBc/Hz -132 dBc/Hz -142 dBc/Hz -142 dBc/Hz	100 Hz 1 kHz 10 kHz 100 kHz 1 MHz 6 MHz 10 MHz
Frequency = 10000 MHz	-64 dBc/Hz -91 dBc/Hz -106 dBc/Hz -106 dBc/Hz -132 dBc/Hz -142 dBc/Hz -142 dBc/Hz	100 Hz 1 kHz 10 kHz 100 kHz 1 MHz 6 MHz 10 MHz

Table 1-3: RF input

Characteristic	Description
RF Input Connector, nominal	N type
RF Input Impedance, nominal	50 Ω
RF VSWR, typical	<1.6 (9 kHz to 10 MHz, RF ATT = 10 dB, Preamp OFF) Center Frequency set to < 200 MHz at time of test.
✓ RF VSWR	Center Frequency must be set within 200 MHz of any VSWR test frequency at time of test.
Preamp OFF, RF ATT = 10 dB	
10 MHz to 4 GHz	<1.6
>4 GHz to 6.2 GHz	<1.8
>6.2 GHz to 14 GHz (RSA6114A)	<1.9
Option 01 Preamp ON	
10 MHz to 3 GHz	<1.9

Table 1-4: Maximum input level

Characteristic	Description
Maximum DC voltage	± 40 V (RF Input)
Maximum safe input power	+30 dBm (RF Input, RF ATT ≥ 10 dB) +75 Watts peak (RF Input, RF ATT ≥ 30 dB (<10 μ s Pulse Width, 1% Duty Cycle repetitive Pulses)
Maximum Measureable input power	+ 30 dBm (RF Input, RF ATT Auto) + 75 Watts peak (RF Input, RF ATT Auto), (<10 μ s Pulse Width, 1% Duty Cycle repetitive pulses)

Table 1-5: Input attenuator

Characteristic	Description
RF Attenuator (9 kHz to 14 GHz)	0 dB to 75 dB (5 dB step), nominal

Table 1-6: Amplitude and RF flatness (excluding mismatch error) ¹

Characteristic	Description
Reference level setting range, nominal	-170 dBm to +50 dBm, 0.1 dB step, (Standard RF input) Minimum ref level -50 dBm at CF < 70 MHz
Frequency response (18 °C to 28 °C)	
✓ 10 dB RF attenuator setting	
10 MHz to 3 GHz Preamp OFF	±0.5 dB
10 MHz to 3 GHz Preamp ON (Option 01 only)	±0.7 dB
3 GHz to 6.2 GHz	±0.8 dB
6.2 GHz to 14 GHz (RSA6114A only)	±1.0 dB
All RF attenuator settings, typical	
9 kHz to 10 MHz	±0.7 dB
Frequency response (0 °C to 50 °C), typical	
All RF attenuator settings	
9 kHz to 10 MHz	±0.7 dB
10 MHz to 3 GHz	±0.7 dB
3 GHz to 6.2 GHz	±0.8 dB
6.2 GHz to 14 GHz (RSA6114A only)	±2.0 dB
Input attenuator switching uncertainty	±0.2 dB
✓ Absolute amplitude accuracy at calibration point (RF)	±0.31 dB
Absolute amplitude accuracy at all center frequencies (18 °C to 28 °C) ² , 95% confidence	
10 MHz to 3 GHz	±0.5 dB
3 GHz to 6.2 GHz	±0.8 dB
6.2 GHz to 14 GHz (RSA6114A only)	±1.5 dB
Level Linearity	±0.1 dB (0 dB to -70 dB Below Reference Level)

¹ All amplitude and frequency response measurements made with Preamp OFF, except where noted, and Flattop window filter used to maximize CW amplitude measurement accuracy.

² Reference Level ≤ -15 dBm, -15 dBm to -50 dBm. 10 Hz ≤ RBW ≤ 1 MHz, after alignment performed.

Table 1-7: Noise and distortion

Characteristic	Description	
1 dB Compression Input		
100 MHz to 3 GHz	>+9 dBm	
3 GHz to 6.2 GHz	>+12 dBm	
6.2 GHz to 14 GHz (RSA6114A only)	>+12 dBm	
3rd Order IM Intercept		
At 2.130 GHz	+15 dBm	+17 dBm, typical
3rd Order Intermodulation Distortion		
✓ Specified		
2.130 GHz	-80 dBc	
Each signal level -25 dBm at the RF input. 1 MHz tone separation. Attenuator = 0, Ref Level = -20 dBm.		
Typical		
9 kHz to 100 MHz	<-77 dBc	
100 MHz to 3 GHz	<-80 dBc	
3 GHz to 6.2 GHz	<-84 dBc	
6.2 GHz to 14 GHz (RSA6114A only)	<-84 dBc	
Each signal level -25 dBm at the RF input. 1 MHz tone separation. Attenuator = 0, Ref Level = -20 dBm.		
2 nd Harmonic Distortion, typical. Preamp OFF		
10 MHz to 3.1 GHz (-40 dBm at RF Input, Atten = 0)	<-80 dBc	
3.1 GHz to 7 GHz (RSA6114A Only) (-25 dBm at RF Input, Atten = 0)	<-80 dBc	

Table 1-7: Noise and distortion (Cont.)

Characteristic	Description	
Displayed Average Noise Level (DANL) Normalized to 1 Hz RBW		
Preamp OFF (best noise mode)	✓ Spec	Typical
9 kHz to 10 MHz	-97 dBm/Hz	-100 dBm/Hz
10 MHz to 100 MHz	-147 dBm/Hz	-149 dBm/Hz
100 MHz to 2.3 GHz	-149 dBm/Hz	-151 dBm/Hz
2.3 GHz to 4 GHz	-147 dBm /Hz	-149 dBm /Hz
4 GHz to 6.2 GHz	-143 dBm /Hz	-145 dBm /Hz
6.2 GHz to 7 GHz (RSA6114A only)	-143 dBm /Hz	-145 dBm /Hz
7 GHz to 14 GHz (RSA6114A only)	-135 dBm /Hz	-137 dBm /Hz
Preamp ON (option 1 only)	✓ Spec	Typical
10 MHz to 50 MHz	-160 dBm/Hz	-170 dBm/Hz
50 MHz to 1 GHz	-165 dBm/Hz	
1 GHz to 2 GHz	-166 dBm/Hz	
2 GHz to 3 GHz	-164 dBm/Hz	

Table 1-8: Channel response ¹

Characteristic	Description
✓Amplitude Flatness	
BW ≤ 300 kHz ²	±0.2 dB
300 kHz < BW ≤ 10 MHz ²	
10 MHz < BW ≤ 20 MHz ²	±0.4 dB
20 MHz < BW ≤ 40 MHz ²	±0.5 dB
40 MHz < BW ≤ 110 MHz ²	±0.9 dB
Phase Linearity, typical	
BW ≤ 300 kHz ²	±0.5°
300 kHz < BW ≤ 10 MHz ²	
10 MHz < BW ≤ 20 MHz ²	±1.0°
20 MHz < BW ≤ 40 MHz ²	±2.0°
40 MHz < BW ≤ 110 MHz ²	

¹ The BW value used in this table is the bandwidth of the channel. RF Attenuator = 10 dB. Use Flattop Window for maximum CW amplitude verification accuracy.

² After calibration and normalization, CF=200 MHz.

Table 1-9: Channel response (center frequency ≤ 3.0 GHz) ¹

Characteristic	Description	
Amplitude Flatness	Specification	Typical
BW ≤ 300 kHz, CF ≤ 0.01 GHz ²	± 0.2 dB ³	0.05 dB _{RMS} ⁴
BW ≤ 40 MHz, CF ≤ 0.03 GHz	± 0.5 dB ³	0.18 dB _{RMS} ⁴
BW ≤ 80 MHz, CF ≤ 0.07 GHz	± 0.9 dB ³	0.4 dB _{RMS} ⁴
BW ≤ 110 MHz, CF ≤ 0.07 GHz		
Phase Linearity, typical		
BW ≤ 300 kHz, CF ≤ 0.01 GHz ²	$\pm 0.5^\circ$ RMS ⁴	
BW ≤ 40 MHz, CF ≤ 0.03 GHz	1.0° RMS ⁴	
BW ≤ 80 MHz, CF ≤ 0.07 GHz	1.5° RMS ⁴	
BW ≤ 110 MHz, CF ≤ 0.07 GHz	2.25° RMS ⁴	

¹ The BW value used in this table is the bandwidth of the channel. Atten = 10 dB. Use Flattop Window for maximum CW amplitude verification accuracy.

² High Dynamic Range mode.

³ After calibration and normalization.

⁴ After calibration and alignment.

Table 1-10: Channel response (3.0 GHz < center frequency ≤ 6.2 GHz) ¹

Characteristic	Description	
Amplitude Flatness	Specification	Typical
BW ≤ 300 kHz ²	±0.2 dB ³	0.05 dB _{RMS} ⁴
BW ≤ 40 MHz	±0.5 dB ³	0.26 dB _{RMS} ⁴
BW ≤ 80 MHz	±0.9 dB ³	0.6 dB _{RMS} ⁴
BW ≤ 110 MHz		
Phase Linearity, typical		
BW ≤ 300 kHz ²	±0.5° _{RMS} ⁴	
BW ≤ 40 MHz	1.0° _{RMS} ⁴	
BW ≤ 80 MHz	1.5° _{RMS} ⁴	
BW ≤ 110 MHz	2.25° _{RMS} ⁴	

¹ The BW value used in this table is the bandwidth of the channel. Atten = 10 dB. Use Flattop Window for maximum CW amplitude verification accuracy.

² High Dynamic Range mode.

³ After calibration and normalization.

⁴ After calibration and alignment.

Table 1-11: Channel response (6.2 GHz < center frequency ≤ 14 GHz, RSA6114A only) ¹

Characteristic	Description	
Amplitude Flatness	Specification	Typical
BW ≤ 300 kHz ²	±0.2 dB ³	0.05 dB _{RMS} ⁴
BW ≤ 40 MHz	±0.8 dB ³	0.40 dB _{RMS} ⁴
40 MHz ≤ BW ≤ 80 MHz	±1.5 dB ³	0.7 dB _{RMS} ⁴
40 MHz ≤ BW ≤ 110 MHz		
Phase Linearity, typical		
BW ≤ 300 kHz ²	1.0° _{RMS} ⁴	
BW ≤ 40 MHz	1.0° _{RMS} ⁴	
40 MHz ≤ BW ≤ 80 MHz	1.5° _{RMS} ⁴	
40 MHz ≤ BW ≤ 110 MHz	2.25° _{RMS} ⁴	

¹ The BW value used in this table is the bandwidth of the channel. Atten = 10 dB. Use Flattop Window for maximum CW amplitude verification accuracy.

² High Dynamic Range mode.

³ After calibration and normalization.

⁴ After calibration and alignment.

Table 1-12: Pulse measurements, typical

Characteristic	Description	
	110 MHz BW	40 MHz BW
Minimum Pulse Width for detection, typical	50 ns	150 ns
Average ON Power (18 °C to 28 °C), typical	±0.3 dB + absolute Amplitude Accuracy	
	For pulsewidths ≥100 ns, duty cycles of 0.5 to 0.001, and S/N ratio = 30 dB	For pulsewidths ≥300 ns, and signal levels >70 dB below Ref Level
Duty Factor, typical	±3% of reading	
	For pulsewidths ≥150 ns, duty cycles of 0.5 to 0.001, and S/N ratio = 30 dB	For pulsewidths ≥450 ns, duty cycles of 0.5 to 0.001, and S/N ratio = 30 dB
Average Transmitted Power, typical	±0.4 dB + absolute Amplitude Accuracy	
	For pulsewidths ≥100 ns, duty cycles of 0.5 to 0.001, and S/N ratio = 30 dB	For pulsewidths ≥300 ns, duty cycles of 0.5 to 0.001, and S/N ratio = 30 dB
Peak Pulse Power, typical	±0.4 dB + absolute Amplitude Accuracy	
	For pulsewidths ≥100 ns, duty cycles of 0.5 to 0.001, and S/N ratio = 30 dB	For pulsewidths ≥300 ns, duty cycles of 0.5 to 0.001, and S/N ratio = 30 dB
Pulse Width, typical	±3% of reading	
	For pulsewidths ≥150 ns, duty cycles of 0.5 to 0.001, and signal levels >50 dB below Ref Level	For pulsewidths ≥450 ns, duty cycles of 0.5 to 0.001, and S/N ratio = 30 dB
System Risetime, typical	<10 ns	<25 ns
Pulse-to-Pulse carrier phase, typical ¹	110 MHz BW	40 MHz BW
	2 GHz	±1.7°
	10 GHz	±3.5°
	60 MHz BW	20 MHz BW
	2 GHz	±1.5°
	10 GHz	±2.9°

¹ For conditions of:
 CW (non-chirped) pulses
 Frequency Estimation = Manual
 Pulse ON power ≥-20 dBm
 Signal peak at Ref Lvl.
 Atten = Auto
 Pulse width ≥ 50 ns.
 PRI ≤3000 us.
 Duty cycle ≥ 0.001
 Phase measurement includes 100 pulses minimum.
 Measured pulses to be adjacent.
 Measurement time position excludes the beginning and ending of the pulse extending for a time = (10/measurement Bandwidth) as measured from the 50% point of the Tr or Tf.

Table 1-13: Spurious response

Characteristic	Description
Residual Response (Atten = 0 dB)	
40 MHz to 200 MHz, typical	<-90 dBm (Ref = -30 dBm, RBW =1 kHz)
✓200 MHz to 6.2 GHz	<-95 dBm (Ref = -30 dBm, RBW =1 kHz)
6.2 GHz to 14 GHz, typical	<-95 dBm (Ref = -30 dBm, RBW =1 kHz)
✓Spurious Response with Signal (Image Suppression)	<-80 dBc (9 kHz to 8 GHz, Ref= -30 dBm, Atten = 10 dB, RF Input Level = -30 dBm, RBW = 10 Hz) <-76 dBc (8 GHz to 14 GHz, Ref= -30 dBm, Atten = 10 dB, RF Input Level = -30 dBm, RBW = 10 Hz)
Spurious Response with Signal	
✓30 MHz to 14 GHz	See Table 1-14
✓Spurious Response with Signal (4.75 GHz - Half-IF)	<-57 dBc (CF 9 kHz to 8 GHz, Ref = -30 dBm, Atten = 10 dB, RBW = 1 kHz) Signal frequency range = 4.7225 to 4.7775 GHz, RF input level = -30 dBm
Local Oscillator Feed-through to Input Connector (Spurious Leakage), typical	<-65 dBm (Attenuator = 10 dB)

Table 1-14: Spurious response with signal

Frequency	Span \leq 40 MHz, Swept Spans < 40 MHz		For Option 110 ¹ , 40 MHz < Span \leq 110 MHz	
	Spec	Typical	Spec	Typical
30 MHz - 6.2 GHz	-73 dBc	-78 dBc	-73 dBc	-75 dBc
\geq 6.2 GHz - 14 GHz (RSA6114A only)	-70 dBc	-75 dBc	-70 dBc	-75 dBc

¹ In 110 mode CF > 80 MHz, after alignment.

Table 1-15: Acquisition

Characteristic	Description
Real-time Capture Bandwidth, nominal	40 MHz (RF, 40 MHz Version) 110 MHz (RF, 110 MHz Version)
Demodulation Bandwidth	40 MHz (RF, 40 MHz Version) 110 MHz (RF, 110 MHz Version)

Table 1- 15: Acquisition (Cont.)

Characteristic	Description			
A/D Converter, nominal	14 bits, 100 Ms/s (40 MHz Version) 14 bits, 100 Ms/s & 12 bits, 300 Ms/s (110 MHz Version)			
Sampling Rate and Available Memory time in RTSA/Time/Demod Mode, nominal	Acquisition BW	Sample Rate (for I and Q)	Record Length	Record Length (Option 02)
	110 MHz (Option 110)	150 MS/s	0.426 s	1.706 s
	60 MHz (Option 110)	75 MS/s	0.852 s	3.413 s
	40 MHz	50 MS/s	1.28 s	5.12 s
	20 MHz	25 MS/s	2.56 s	10.2 s
	10 MHz	12.5 MS/s	5.12 s	20.5 s
	5 MHz	6.25 MS/s	10.2 s	41.0 s
	2 MHz	3.125 MS/s	10.2 s	41.0 s
	1 MHz	1.56 MS/s	20.5 s	81.9 s
	500 kHz	781 kS/s	41 s	164 s
	200 kHz	390 kS/s	81.9 s	328 s
	100 kHz	195 kS/s	164 s	655 s
	50 kHz	97.6 kS/s	328 s	1310 s
	20 kHz	48.8 kS/s	655 s	2620 s
	10 kHz	24.4 kS/s	1310 s	10500 s
	5 kHz	12.2 kS/s	2620 s	21000 s
	2 kHz	3.05 kS/s	10500 s	41900 s
1 kHz	1.52 kS/s	21000 s	83900 s	
500 Hz	762 S/s	41900 s	168300 s	
200 Hz	381 S/s	83900 s	336000 s	
100 Hz	190 S/s	168300 s	671000 s	
Minimum Acquisition Length in RTSA/Time/Demod Mode, nominal	64 samples			
Maximum Acquisition Length in RTSA/Time/Demod Mode (Acquisition BW Dependent), nominal	53,687,000 samples (Std.) 214,748,000 samples (Option 02)			
Acquisition Length Setting resolution in RTSA/Time/Demod Mode, nominal	1 sample			
Fast Frame Acquisition Mode	Up to 65,535 records can be stored in a single acquisition (for Pulse Measurements and Spectrogram Analysis)			
Acquisition Memory Size				
Acq BW > 2.5 MHz (256 Mbyte) (Std)	64 MSamples			
Acq BW ≤ 2.5 MHz (256 Mbyte) (Std)	32 MSamples			
Acq BW > 2.5 MHz (1 Gbyte) (Option02)	256 MSamples			
Acq BW ≤ 2.5 MHz (1 Gbyte) (Option02)	128 MSamples			

Table 1-16: Amplitude vs. time

Characteristic	Description
Time Scale (Zero Span), nominal	400 ns min to 2000 s max (Option 110) 1 μ s min to 2000 s max (Option 40)
Time Accuracy	$\pm 0.5\%$ of total time
Time Resolution	0.1% of total time
Time Linearity	$\pm 0.5\%$ of total time (measured at 11 equally-spaced points across the display, including the ends)

Table 1-17: Trigger

Characteristic	Description
Trigger Mode, Type, & Source, nominal	Modes: Free Run (Triggered by the end of the preceding acquisition) Triggered (Triggered by Event) Triggered Sequential (Triggered by Event, sequential storage of acquisitions) Types: Single (one acquisition from one trigger) Continuous (repeated acquisitions from repeating triggers) Sources: RF Input Trigger 1 (Front) Trigger 2/Gate (Rear) Gated (Logical AND of the selected edge [rising or falling] of Trigger 1 and the selected level [low or high] of Trigger 2) Line
Trigger Event Type (RF Source)	Power Level (IF Span BW after RBW and VBW filters) Frequency Mask (Op.02)
Trigger Event Delay Range, nominal	20 ns to 60 s
Trigger Event Delay Resolution, nominal	20 ns
Trigger Event Delay Uncertainty, nominal	± 20 ns
Pre/Post Trigger Setting, nominal	Trigger Position is settable within 0% to 100% of Total Data Length
Power Trigger Level Range, nominal	0 dB to -100 dB from Reference Level
Power Trigger Level Resolution, nominal	0.1 dB
Power Trigger Level Accuracy (With respect to full-scale)	± 0.5 dB (level ≥ -50 dB from Reference Level) for trigger levels >30 dB above noise floor ± 1.5 dB from (-50 dB to -70 dB from Reference Level) for trigger levels >30 dB above noise floor This applies when the Trigger Level is between 10% and 90% of the signal amplitude

Table 1-17: Trigger (Cont.)

Characteristic	Description
Power Trigger Position Timing Uncertainty, typical	± 10 ns for 40 MHz Acq BW using 20 MHz trigger RBW ± 3.3 ns for 110 MHz Acq BW using 60 MHz trigger RBW
Trigger Rearm Time, minimum (FastFrame ON)	
10 MHz acquisition BW	≤ 25 μ s
40 MHz acquisition BW	≤ 10 μ s
110 MHz acquisition BW (Opt. 110)	≤ 5 μ s
Power Trigger Bandwidth setting, nominal	Not an independent setting. This is set by the "Time Domain Bandwidth" control
Frequency Mask Trigger Mask Point Horizontal Resolution (Option 02), nominal	$< 0.2\%$ of span
Frequency Mask Trigger Level Range (Option 02), nominal	0 to -80 dB from reference level for spans ≤ 40 MHz (RSA6106A, RSA6114A) for spans ≤ 110 MHz (Option 110)
Frequency Mask Trigger Level Resolution (Option 02), nominal	0.1 dB
Frequency Mask Trigger Level Accuracy (Option 02) (with respect to Reference Level)	\pm (Channel Response Flatness + 1 dB) (for mask levels ≥ -50 dB) for masks > 30 dB above the noise floor \pm (Channel Response Flatness + 2.5 dB) (for mask levels of -50 dB to -70 dB) for masks > 30 dB above the noise floor
Frequency Mask Trigger Max Real-time Event Detection Bandwidth (Option 02), nominal	40 MHz (1024 point FFT, 50% overlapping, Base Unit) 110 MHz (1024 point FFT, 50% overlapping, Option 110)
Frequency Mask Trigger Real-time Event Minimum Duration for 100% probability of trigger (Option 02), nominal	30.7 μ s at 40 MHz span (Base Unit) 10.3 μ s at 110 MHz span (Option 110)
Frequency Mask Trigger Timing Uncertainty	± 12.8 μ s at 40 MHz span (Base Unit) ± 5.12 μ s at 110 MHz span (Option 110)
External Trigger 1 Threshold Voltage, nominal	Variable: -2.5 V to +2.5 V settable
External Trigger 2 Threshold Voltage, nominal	Fixed: TTL
External Trigger 1 Threshold Voltage Setting Resolution, nominal	0.01 V
External Trigger 1 Input Impedance, nominal	Selectable: 50 Ω or 5 k Ω
External Trigger 2 Input Impedance, nominal	Fixed: 10 k Ω
External Trigger 1 Timing Uncertainty (50 Ω impedance only)	
>75 MHz to 110 MHz acquisition BW	± 12 ns
>40 MHz to 75 MHz acquisition BW	± 15 ns

Table 1-17: Trigger (Cont.)

Characteristic	Description
>20 MHz to 40 MHz acquisition BW	±20 ns
Trigger Output Voltage, nominal (Output Current < 1mA)	HIGH: > 2.0 V LOW: < 0.4 V
Trigger Output Impedance, nominal	50 Ω
Power Trigger Output Position Timing Uncertainty	±2 sample points (Decimated clock periods, see Table 1-18)
Trigger Holdoff Time Resolution, nominal	10 ns minimum
Trigger Holdoff Time Accuracy, nominal	Total Holdoff Time x Reference Oscillator Accuracy

Table 1-18: Decimated clock period¹

Power Trigger Time Domain Bandwidth	Decimated clock period	
	Standard (40 MHz span)	Option 110 (110 MHz span)
60 MHz (Option 110 only)	NA	6.67 ns
20 MHz	20 ns	6.67 ns
10 MHz	20 ns	6.67 ns
1 MHz	80 ns	53.4 ns
100 kHz	640 ns	854 ns
10 kHz	5.12 μs	N/A

¹ The decimated clock period is used for determining the Power Trigger Output Position Timing Uncertainty. See Power Trigger Output Position Timing Uncertainty in Table 1-17 on page 1-15.

Table 1-19: Resolution bandwidth filter (SA mode)

Characteristic	Description
Filter Shape, nominal	Gaussian-like (Actual filter shape is Kaiser with $\beta = 16.72$)
Bandwidth Accuracy	1.0% (Auto-coupled)
Range, nominal	See Table 1-20
Resolution, nominal	1, 2, 3, 5 (for sequence selection) 1% (for user-entry mode)
Minimum Settable RBW, nominal	See Table 1-20
Shape Factor, typical	4.1:1 (60 dB:3 dB) (±10%)

Table 1-20: Range and settable RBW (SA mode)

Acquisition BW	Frequency Domain Resolution Bandwidth Range	
	Maximum RBW	Minimum RBW
110 MHz (Option 110)	5 MHz	100 Hz
60 MHz (Option 110)	5 MHz	100 Hz
40 MHz	5 MHz	100 Hz
20 MHz	5 MHz	100 Hz
10 MHz	2 MHz	10 Hz
5 MHz	1 MHz	10 Hz
2.5 MHz	625 kHz	10 Hz
1.25 MHz	312 kHz	1 Hz
625 kHz	156 kHz	1 Hz
312.5 kHz	78 kHz	1 Hz
156.25 kHz	39 kHz	1 Hz
78.125 kHz	20 kHz	1 Hz
39.0625 kHz	10 kHz	1 Hz
19.53125 kHz	5 kHz	1 Hz
9.765625 kHz	2 kHz	1 Hz
4.8828125 kHz	1 kHz	1 Hz
2.44140625 kHz	610 Hz	1 Hz
1.220703125 kHz	305 Hz	1 Hz
610.3515625 Hz	152 Hz	1 Hz
305.17578125 Hz	76 Hz	1 Hz
152.587890625 Hz	38 Hz	1 Hz

Table 1-21: Resolution bandwidth filter (time-domain mode)

Characteristic	Description
Filter Shape, nominal	Gaussian-like (Actual filter shape is Kaiser with $\beta = 16.72$)
Shape Factor, typical	4.1:1 (60 dB:3 dB) ($\pm 10\%$) for filters up to 10 MHz < approximately 2.5:1 (60 dB:3 dB) for filters >10 MHz to 60 MHz
Range, nominal	See Table 1-22
Bandwidth Accuracy	1 Hz to 10 MHz = 1% (Auto-coupled) 20 MHz & 60 MHz = 10%

Table 1-21: Resolution bandwidth filter (time-domain mode) (Cont.)

Characteristic	Description
Resolution, nominal	1, 2, 3, 5 (plus 60 MHz for Option 110) (for sequence selection) 1% (for user-entry mode)
Minimum Settable RBW, nominal	See Table 1-22

Table 1-22: Range and settable RBW (time-domain mode)

Acquisition BW	Time Domain Trigger And Amplitude vs. Time Bandwidth Range (plus “wide open”) ¹	
	Maximum TDBW ¹	Minimum TDBW
110 MHz (Opt 110)	60 MHz	11 kHz
60 MHz (Opt 110)	7.5 MHz	6 kHz
40 MHz	20 MHz	4 kHz
20 MHz	2.5 MHz	2 kHz
10 MHz	1.25 MHz	1 kHz
5 MHz	625 kHz	500 Hz
2.5 MHz	312.5 kHz	250 Hz
1.25 MHz	156.25 kHz	125 Hz
625 kHz	78.125 kHz	62.5 Hz
312.5 kHz	39.0625 kHz	31.25 Hz
156.25 kHz	19.53125 kHz	15.625 Hz
78.125 kHz	9.765625 kHz	7.8125 Hz
39.0625 kHz	4.8828125 kHz	3.90625 Hz
19.53125 kHz	2.44140625 kHz	1.953125 Hz
9.765625 kHz	1.220703125 kHz	1 Hz
4.8828125 kHz	610.3515625 Hz	1 Hz
2.44140625 kHz	305.17578125 Hz	1 Hz
1.220703125 kHz	152.587890625 Hz	1 Hz
610.3515625 Hz	76.2939453125 Hz	1 Hz
305.17578125 Hz	38.14697265625 Hz	1 Hz
152.587890625 Hz	19.073486328125 Hz	1 Hz

¹ Time Domain Trigger bandwidth can always be set to “Wide Open”, equal to the acquisition BW

Table 1-23: Preamp (Option 01)

Characteristic	Description
Noise Figure	<4 dB at 2 GHz
Bandwidth	10 MHz to 3 GHz

Table 1-24: IF output (Option 05)

Characteristic	Description
Output Level, typical	-10 dBm to +3 dBm for peak level of -20 dBm at the RF Mixer
Output Frequency, typical	500 MHz. Varies ± 1 MHz with changes in center frequency
IF Filter, typical	Selectable: 60 MHz Gaussian to -12 dB, or 150 MHz "wide-open"
Spurious	May contain spurious signals as high as -75 dBc

Table 1-25: Digital IQ output¹

Characteristic	Min	Max
Differential Output voltage magnitude ($R_{LOAD} = 100 \Omega$)	247 mV	454 mV
Steady state common mode output voltage	1.125 V	1.375 V

¹ LVDS signaling - ANSI EIA/TIA-644 standard

Table 1-26: 28 Volt noise source drive output

Characteristic	Description
Output Level, nominal	28 VDC @ 140 mA

Electrical Functional Specifications

Table 1-27: Measurement function

Characteristic	Description
Power and Frequency Domain Measurement Functions, nominal	Channel Power, Adjacent Channel Power, Multi-carrier Adjacent Channel Power/Leakage Ratio, Occupied Bandwidth xdB Down dBm/Hz Marker dBc/Hz Marker
Time Domain and Statistical Measurement Functions, nominal	RF I/Q vs. Time, Power vs. Time, Frequency vs. Time, Phase vs. Time, CCDF, Peak-to-Average Ratio
Advanced Measurements Suite (Option 20), nominal	Rise Time, Fall Time, Pulse Width, Pulse Peak Power, Pulse Average Power, Pulse Ripple, Pulse Repetition Interval, Duty Cycle, Pulse-to-Pulse Phase Pulse Frequency, Pulse Frequency Error, Pulse Phase Pulse Phase Error Droop, Trend, FFT of Trend
General Purpose Digital Modulation Analysis (Option 21), nominal	EVM (RMS, Peak, EVM vs. Time) Magnitude Error (RMS, Peak, Magnitude Error vs. Time) Phase Error (RMS, Peak, Phase Error vs. Time) Waveform Quality (RHO) Frequency Error Origin Offset Gain Imbalance Quadrature Error Constellation Symbol Table

Table 1-28: Views by domain

Characteristic	Description
Frequency, nominal	Spectrum (Amplitude vs. Frequency) DPX™ Spectrum Display (Live RF color-graded spectrum) Spectrogram (Amplitude vs. Frequency over Time)
Time and Statistics, nominal	Frequency vs. Time Amplitude vs. Time Phase vs. Time RF I&Q vs. Time Time Overview CCDF Peak-Average-Ratio
Advanced Measurements Suite (Option 20), nominal	Pulse Results Table Pulse Trace (Selectable by pulse number) Pulse Statistics (Trend of Pulse Results and FFT of Trend)
General Purpose Digital Modulation Analysis (Option 21), nominal	Constellation Diagram I/Q vs. Time EVM vs. Time Symbol Table (Binary or Hexadecimal)

Table 1-29: Analog demodulation accuracy

Characteristic	Description
Amplitude vs. Time Accuracy, typical	±1% (-10 dBfs Input at center, 5% to 95% Modulation Depth)
Phase vs. Time Accuracy, typical	±0.1° for modulations <180°, and rates <500 kHz. (-10 dBfs Input at center)
Frequency vs. Time Accuracy, typical	±0.1% of Span for deviations < 2 MHz, and modulation frequencies < 500 kHz. (-10 dBfs Input at center)

Table 1-30: Frequency and phase error referenced to non-chirped signal¹

Bandwidth	Center Frequency = 2 GHz			Abs. Freq. Error (rms)	Center Frequency = 10 GHz	
	Abs. Freq. Error (rms)	Pulse-Pulse Frequency	Pulse-Pulse Phase		Pulse-Pulse Frequency	Pulse-Pulse Phase
BW: 20 MHz	±50 kHz	±100 kHz	±1.7 °	±100 kHz	±50 kHz	±3.2 °
BW: 40 MHz	±50 kHz	±100 kHz	±1.7 °	±125 kHz	±50 kHz	±3.7 °
BW: 60 GHz (Opt. 110)	±200 kHz	±350 kHz	±1.9 °	±450 kHz	±50 kHz	±4 °
BW: 110 MHz (Opt. 110)	±300 kHz	±550 kHz	±2 °	±700 kHz	±1.3 MHz	±5 °

Table 1-31: Frequency and phase error referenced to a linear chirp¹

Bandwidth	Center Frequency = 2 GHz			Abs. Freq. Error (rms)	Center Frequency = 10 GHz	
	Abs. Freq. Error (rms)	Pulse-Pulse Frequency	Pulse-Pulse Phase		Pulse-Pulse Frequency	Pulse-Pulse Phase
BW: 20 MHz	±200 kHz	±100 kHz	±2.2 °	±300 kHz	±200 kHz	±4 °
BW: 40 MHz	±300 kHz	±100 kHz	±2.2 °	±400 kHz	±250 kHz	±5 °
BW: 60 GHz (Opt. 110)	±900 kHz	±550 kHz	±2.4 °	±1.3 MHz	±1.1 MHz	±6.5 °
BW: 110 MHz (Opt. 110)	±1.9 MHz	±650 kHz	±2.5 °	±2.0 MHz	±1.6 MHz	±7.0 °

¹ At the following frequencies and bandwidths, 95% confidence. Pulse ON power ≥ -20 dBm, signal peak at reference level, Attenuator = Auto, $t_{meas} - t_{reference} \leq 10$ ms, Frequency Estimation: Manual. Pulse-to-Pulse measurement time position excludes the beginning and ending of the pulse extending for a time = $(10/\text{Measurement BW})$ as measured from 50% of the $t_{(rise)}$ or $t_{(fall)}$. Absolute Frequency Error determined over center 50% of pulse.

Table 1-32: General purpose digital modulation analysis (Option 21)

Characteristic	Description
Carrier Type, nominal	Continuous, Burst (5 μs minimum on-time)
Analysis Period, nominal	Up to 80,000 samples
Modulation Format Presets, nominal	BPSK, QPSK, DQPSK, $\pi/4$ DQPSK, D8PSK, 8PSK, 16QAM, 64QAM, 256QAM, GMSK, GFSK
Measurement Filter, nominal	Root Raised Cosine, Raised Cosine, Gaussian, Rectangular, IS-95 Base EQ, None
Reference Filter, nominal	Gaussian, Raised Cosine, Rectangular, IS-95 baseband, None

Table 1-32: General purpose digital modulation analysis (Option 21) (Cont.)

Characteristic	Description
Filter Rolloff Factor, nominal	α :0.001 to 1, 0.001 step
Maximum Symbol Rate, nominal	100 Ms/s (Option 110)
Standard Setup Presets, nominal	None
Measurement Functions, nominal	Constellation, EVM, Symbol Table
Vector Diagram Display Format, nominal	Symbol/Locus Display, Frequency Error Measurement, Origin Offset Measurement
Constellation Diagram Display Format, nominal	Symbol Display, Frequency Error Measurement, Origin Offset Measurement
Eye Diagram Display Format, nominal	None
Error Vector Diagram Display Format, nominal	EVM, Magnitude Error, Phase Error, Waveform Quality (Q) Measurement Frequency Error Measurement Origin Offset Measurement
Symbol Table Display Format, nominal	Binary, Hexadecimal
Digital Demodulation Accuracy, typical	CF = 2 GHz 0.7 % (1 MHz symbol rate), 1.0 % (10 MHz symbol rate), 3.0 % (30 MHz symbol rate), 3.0 % (80 MHz symbol rate)

Table 1-33: Digital demodulation accuracy (Option 21)

Characteristic	Description
QPSK Residual EVM, typical	
CF	2 GHz
Symbol Rate	
100 kHz	0.6%
1 MHz	0.7%
10 MHz	1.0%
30 MHz	3.0%
80 MHz	3.0%
256 QAM Residual EVM, typical	
CF	2 GHz

Table 1-33: Digital demodulation accuracy (Option 21) (Cont.)

Characteristic	Description
Symbol Rate	
10 MHz	1.0%
30 MHz	3.0%
80 MHz	3.0%

Table 1-34: ACLR measurement

Characteristic	Description
ACLR (3GPP Down Link, 1 DPCH) (2130 MHz), typical	-70 dBc (Adjacent Channel) -79 dBc w/Noise Correction ACPR (Adjacent Channel) -70 dBc (First Alternate Channel) -79 dBc w/Noise Correction (First Alternate Channel)
ACLR (3GPP TM1 64 channel) (2130 MHz), typical	-69 dBc (Adjacent Channel) -78 dBc w/Noise Correction ACPR (Adjacent Channel) -69 dBc (First Alternate Channel) -78 dBc w/Noise Correction (First Alternate Channel)

Table 1-35: Digital phosphor spectrum processing (DPx)

Characteristic	Description
Spectrum Processing Rate, nominal	48,833 per second (Span Independent)
Min Signal Duration for 100% Probability of Intercept, typical	31 μ s (Base Unit) 24 μ s (Option 110)
Span Range, nominal	100 Hz to 40 MHz 100 Hz to 110 MHz (Option 110)

Table 1-35: Digital phosphor spectrum processing (DPx) (Cont.)

Characteristic	Description	
RBW Settings, nominal	Acquisition Bandwidth	RBW (Min)
	110 MHz	640 kHz
	55 MHz	320 kHz
	40 MHz	214 kHz
	20 MHz	107 kHz
	10 MHz	53.3 kHz
	5 MHz	26.7 kHz
	2 MHz	13.4 kHz
	1 MHz	6.66 kHz
	500 kHz	3.33 kHz
	200 kHz	1.67 kHz
	100 kHz	833 kHz
	50 kHz	417 Hz
	20 kHz	209 Hz
	10 kHz	105 Hz
	5 kHz	52 Hz
	2 kHz	13.1 Hz
	1 kHz	6.51 Hz
	500 Hz	3.26 Hz
200 Hz	1.63 Hz	
100 Hz	0.819 Hz	
RBW Accuracy	7%	

Physical Characteristics

Table 1-36: Physical characteristics

Characteristic	Description	
Dimensions	mm	in.
Width (handles folded in)	473	18.6
Height (with feet, without accessory pouch)	282	11.1
Length	531	20.9

Table 1-36: Physical characteristics (Cont.)

Characteristic	Description	
	kg	lb.
Weight (without accessories)		
Net	26.3	58.0

Table 1-37: Display/computer

Characteristic	Description
LCD Panel Size	264 mm (10.4 in)
Display Resolution	1024 x 768 pixels
Colors	256 colors (Maximum)
CPU	Intel Celeron M 1.3 GHz
DRAM	512 MB DIMM (Standard) 1 GB DIMM (Opt 02)
OS	WindowsXP
System Bus	PCI
Hard Disk Drive	3.5 inch IDE
Printer Port	USB
GPIB	IEEE488.2
LAN	10/100/1000 Base-T
Mouse	USB
Keyboard	USB or PS2
Monitor Out	VGA (D-SUB 15 pin)

Safety

EC Declaration of Conformity - Low Voltage

Compliance was demonstrated to the following specification as listed in the Official Journal of the European Communities:

Low Voltage Directive 73/23/EEC, amended by 93/68/EEC.

- EN 61010-1:2001. Safety requirements for electrical equipment for measurement control and laboratory use.

U.S. Nationally Recognized Testing Laboratory Listing

- UL 61010-1:2004, 2nd Edition. Standard for electrical measuring and test equipment.

Canadian Certification

- CAN/CSA C22.2 No. 61010-1:2004. Safety requirements for electrical equipment for measurement, control, and laboratory use. Part 1.

Additional Compliance

- IEC 61010-1:2001. Safety requirements for electrical equipment for measurement, control, and laboratory use.

Equipment Type

Test and measuring equipment.

Safety Class

Class 1 - grounded product

Pollution Degree Descriptions

A measure of the contaminates that could occur in the environment around and within a product. Typically the internal environment inside a product is considered to be the same as the external. Products should be used only in the environment for which they are rated.

- Pollution Degree 1. No pollution or only dry, nonconductive pollution occurs. Products in this category are generally encapsulated, hermetically sealed, or located in clean rooms.
- Pollution Degree 2. Normally only dry, nonconductive pollution occurs. Occasionally a temporary conductivity that is caused by condensation must be expected. This location is a typical office/home environment. Temporary condensation occurs only when the product is out of service.
- Pollution Degree 3. Conductive pollution, or dry, nonconductive pollution that becomes conductive due to condensation. These are sheltered locations where neither temperature nor humidity is controlled. The area is protected from direct sunshine, rain, or direct wind.

- Pollution Degree 4. Pollution that generates persistent conductivity through conductive dust, rain, or snow. Typical outdoor locations.

Pollution Degree Pollution Degree 2 (as defined in IEC 61010-1). Note: Rated for indoor use only.

Certifications and Compliances

EC Declaration of Conformity - EMC

Meets intent of Directive 89/336/EEC for Electromagnetic Compatibility. Compliance was demonstrated to the following specifications as listed in the Official Journal of the European Communities:

EN 61326. EMC requirements for Class A electrical equipment for measurement, control, and laboratory use. Annex D. ^{1, 2, 3, 4}

- IEC 61000-4-2. Electrostatic discharge immunity
- IEC 61000-4-3. RF electromagnetic field immunity ^{5, 6}
- IEC 61000-4-4. Electrical fast transient / burst immunity
- IEC 61000-4-5. Power line surge immunity
- IEC 61000-4-6. Conducted RF Immunity ⁷
- IEC 61000-4-11. Voltage dips and interruptions immunity

EN 61000-3-2. AC power line harmonic emissions

EN 61000-3-3. Voltage changes, fluctuations, and flicker

Australia / New Zealand Declaration of Conformity - EMC

Complies with EMC provision of Radiocommunications Act per these standard(s):

- AS/NZS CISPR11, Class A. ^{1, 2, 3}

EMC Compliance

Meets the intent of Directive 89/336/EEC for Electromagnetic Compatibility when it is used with the product(s) stated in the specifications table. Refer to the EMC specification published for the stated products. May not meet the intent of the directive if used with other products.

¹ Emissions compliance demonstrated to Class A requirements, applicable to non-residential locations of use, only.

² Compliance demonstrated using high quality, shielded interface cables.

³ Emissions that exceed the limits of this standard may occur when the equipment is connected to a test object.

⁴ EN61326 Minimum Immunity Test Requirement applied.

- 5 Performance Criteria with disturbance signal frequencies within 55 MHz of EUT Center Frequency: Residential spurious signals can increase to 55 dB below the EUT Reference Level, with exposure to the disturbance levels of this test.
- 6 Performance Criteria with disturbance signal frequencies more than 55 MHz away from the EUT Center Frequency: Residual spurious signals can increase to 75 dB below the EUT Reference Level, with exposure to the disturbance levels of this test.
- 7 Performance Criteria: Residual spurious signals can increase to 75 dB below the EUT Reference Level, with exposure to the disturbance levels of this test.

Environmental Characteristics

Table 1-38: Environmental characteristics

Characteristic	Description
Temperature range ¹	
Operating	+5 °C to +50 °C
When accessing DVD	+5 °C to +40 °C
Non-operating	-20 °C to +60 °C
Relative Humidity	90% RH at 30 °C (No condensation) (80% RH max when accessing CD) Maximum wet-bulb temperature 29 °C
Altitude	
Operating	Up to 3000 m (approximately 10000 ft)
Non-operating	Up to 12190 m (40000 ft)
Vibration	
Operating	0.22 Grms. Profile = 0.00010 g ² /Hz at 5 Hz to 350 Hz, -3dB/Octave slope from 350 Hz to 500 Hz, 0.00007 g ² /Hz at 500 Hz, 3 Axes at 10 min/axis (Except when equipped with Option 06 Removable HDD, or when accessing DVD/CD) When equipped with Option 08, Removable Solid State Hard Drive 0.24 Grms. Profile - 0.000125 g ² /Hz at 5 Hz to 350 Hz, -3dB/Octave slope from 350 Hz to 500 Hz, 0.0000876 g ² /Hz at 500 Hz, 3 Axes at 10 min/axis
Non-operating	2.28 Grms. Profile = 0.015 g ² /Hz at 5 Hz to 100 Hz, -3 dB/Octave slope from 100 Hz to 200 Hz, 0.075 g ² /Hz at 200 Hz to 350 Hz, -3dB/Octave slope from 350 Hz to 500 Hz, 0.00526 g ² /Hz at 500 Hz, 3 Axes at 10 min/axis
Shock	
Operating	(15 G), half-sine, 11 ms duration. Three shocks per axis in each direction (18 shocks total) (1 G max when accessing DVD) (DVD tray ejection may occur)
Non-operating	296 m/s ² (30 G), half-sine, 11 ms duration. Three shocks per axis in each direction (18 shocks total) (DVD tray ejection may occur)
Cooling Clearance	
Bottom	20 mm (0.79 in)
Both Sides	50 mm (1.97 in)

Table 1-38: Environmental characteristics (Cont.)

Characteristic	Description
Back	50 mm (1.97 in)
¹	Measured one inch (2.5 cm) away from the ventilation air intake (located at the left side of the instrument when viewed from the front).

Table 1-39: Power Requirements

Characteristic	Description
Voltage range	
50 Hz/60 Hz	90 V - 264 V
400 Hz	90 V - 132 V
Maximum Power dissipation (fully loaded)	
Maximum power	600 W
Maximum line current	7.3 Amps at 50 Hz, 90 V line
Surge Current	MAX 52 A peak (25 °C) for ≤5 line cycles, after product has been turned off for at least 30 s.

Digital IQ Output Connector Pin Assignment (Option 05 Only)

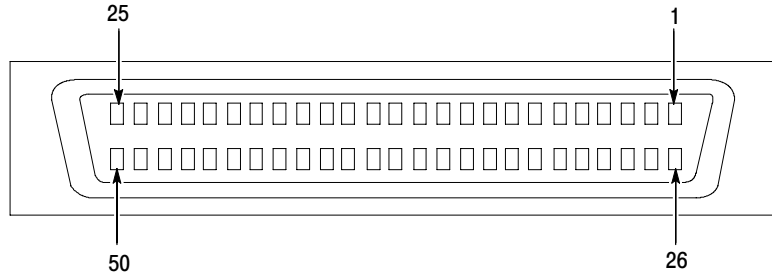

Figure 1-1: Digital IQ output connector pin assignment

Table 1-40: I OUTPUT connector pin assignment

Pin number	Signal name	Description
1	IQ_ENABLE*	IQ output enable signal input Open: IQ output disable GND: IQ output enable
26	GND	Ground
2	EXT_IQ_MSW-	Reserved for future use
27	EXT_IQ_MSW+	
3	EXT_I0-	I output data (bit 0), LVDS
28	EXT_I0+	
4	EXT_I1-	I output data (bit 1), LVDS
29	EXT_I1+	
5	EXT_I2-	I output data (bit 2), LVDS
30	EXT_I2+	
6	EXT_I3-	I output data (bit 3), LVDS
31	EXT_I3+	
7	GND	Ground
32	GND	
8	EXT_I4-	I output data (bit 4), LVDS
33	EXT_I4+	
9	EXT_I5-	I output data (bit 5), LVDS
34	EXT_I5+	
10	EXT_I6-	I output data (bit 6), LVDS
35	EXT_I6+	

Table 1-40: I OUTPUT connector pin assignment (Cont.)

Pin number	Signal name	Description
11	EXT_I7-	I output data (bit 7), LVDS
36	EXT_I7+	
12	GND	Ground
37	GND	
13	EXT_I8-	I output data (bit 8), LVDS
38	EXT_I8+	
14	EXT_I9-	I output data (bit 9), LVDS
39	EXT_I9+	
15	EXT_I10-	I output data (bit 10), LVDS
40	EXT_I10+	
16	EXT_I11-	I output data (bit 11), LVDS
41	EXT_I11+	
17	GND	Ground
42	GND	
18	EXT_I12-	I output data (bit 12), LVDS
43	EXT_I12+	
19	EXT_I13-	I output data (bit 13), LVDS
44	EXT_I13+	
20	EXT_I14-	I output data (bit 14), LVDS
45	EXT_I14+	
21	EXT_I15-	I output data (bit 15), LVDS
46	EXT_I15+	
22	GND	Ground
47	GND	
23	GND	
48	GND	
24	EXT_IQ_DAV-	IQ Data Valid indicator, LVDS
49	EXT_IQ_DAV+	
25	EXT_IQ_CLK-	IQ output clock, LVDS
50	EXT_IQ_CLK+	

Table 1-41: Q OUTPUT connector pin assignment

Pin number	Signal name	Description
1	IQ_ENABLE*	IQ output enable signal input Open: IQ output disable GND: IQ output enable
26	GND	Ground
2	GND	
27	GND	
3	EXT_Q0-	Q output data (bit 0), LVDS
28	EXT_Q0+	
4	EXT_Q1-	Q output data (bit 1), LVDS
29	EXT_Q1+	
5	EXT_Q2-	Q output data (bit 2), LVDS
30	EXT_Q2+	
6	EXT_Q3-	Q output data (bit 3), LVDS
31	EXT_Q3+	
7	GND	Ground
32	GND	
8	EXT_Q4-	Q output data (bit 4), LVDS
33	EXT_Q4+	
9	EXT_Q5-	Q output data (bit 5), LVDS
34	EXT_Q5+	
10	EXT_Q6-	Q output data (bit 6), LVDS
35	EXT_Q6+	
11	EXT_Q7-	Q output data (bit 7), LVDS
36	EXT_Q7+	
12	GND	Ground
37	GND	
13	EXT_Q8-	Q output data (bit 8), LVDS
38	EXT_Q8+	
14	EXT_Q9-	Q output data (bit 9), LVDS
39	EXT_Q9+	
15	EXT_Q10-	Q output data (bit 10), LVDS
40	EXT_Q10+	

Table 1-41: Q OUTPUT connector pin assignment (Cont.)

Pin number	Signal name	Description
16	EXT_Q11-	Q output data (bit 11), LVDS
41	EXT_Q11+	
17	GND	Ground
42	GND	
18	EXT_Q12-	Q output data (bit 12), LVDS
43	EXT_Q12+	
19	EXT_Q13-	Q output data (bit 13), LVDS
44	EXT_Q13+	
20	EXT_Q14-	Q output data (bit 14), LVDS
45	EXT_Q14+	
21	EXT_Q15-	Q output data (bit 15), LVDS
46	EXT_Q15+	
22	GND	Ground
47	GND	
23	GND	
48	GND	
24	GND	
49	GND	
25	GND	
50	GND	

Table 1-42: Mating connections

Recommendation	Description
Mating cable	Tektronix part number 174-5194-00
Mating connector	3M N10250-52E2PC

Digital IQ Output Timing

All I/Q output signals are synchronous to clock EXT_IQ_CLK. The clock operates at either 50 MHz or 150 MHz, depending on the selected real-time span of the RSA6100A (see Table 1-44, IQ Timing).

Data is valid when the EXT_IQ_DAV signal is asserted high; data is invalid when EXT_IQ_DAV is low. The EXT_IQ_DAV duty cycle varies with the real-time SPAN, as shown in Table 1-43. At spans where the duty cycle is less than 100%, the EXT_IQ_DAV signal is high for one clock cycle, then low for one or more clock cycles.

Table 1-43: EXT_IQ_DAV Duty cycle versus Span

Span	EXT_IQ_CLK frequency (MHz)	EXT_IQ_DAV duty cycle (%)
110 MHz	150	100.0
60 MHz	150	50.0
40 MHz	50	100.0
20 MHz	50	50.0
10 MHz	50	25.0
5 MHz	50	12.5
2 MHz	50	6.250
1 MHz	50	3.125
500 kHz	50	1.5625
200 kHz	50	0.78125
100 kHz	50	0.39063
50 kHz	50	0.19531
20 kHz	50	0.097656
10 kHz	50	0.048828
5 kHz	50	0.024414
2 kHz	50	0.006104
1 kHz	50	0.003052
500 kHz	50	0.001526
200 kHz	50	0.000763
100 kHz	50	0.000381

The rising edge of EXT_IQ_CLK is aligned to be in the center of the settled EXT_I[15:0], EXT_Q[15:0], and EXT_IQ_DAV signals.

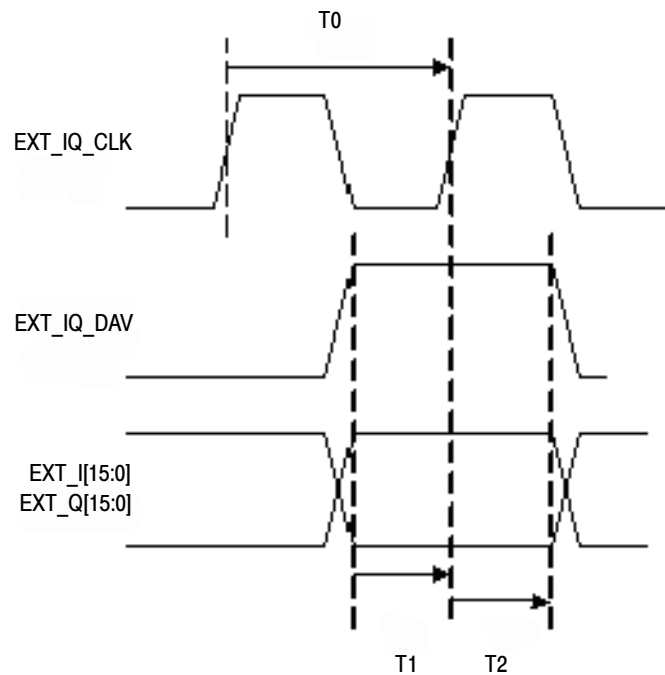

Figure 1-2: IQ Timing

Table 1-44: IQ Timing

Real Time Span	T0 (Clock Period)	T1 (Setup Time)	T2 (Hold Time)
>40 MHz	6.6 ns	1.54 ns	1.58 ns
≤40 MHz	20 ns	8.2 ns	8.4 ns

Possible Interruption of Data from Digital I/Q Outputs

There are three conditions during which the RSA6100A will interrupt the flow of data to the digital I/Q outputs. Those conditions are:

- Alignments
- Control Changes
- Stitched Spectrum Mode

When any of these conditions are active, the EXT_IQ_DAV signal will be held in its inactive state. The EXT_IQ_CLK signal will remain active and operate at the frequency consistent with the SPAN value selected for the RSA6100A.

The EXT_IQ_DAV signal will remain inactive for the duration of any alignment or control change. Once the alignment or control change has been completed, the EXT_IQ_DAV signal becomes active again. While the EXT_IQ_DAV signal is

inactive, the data from the digital I/Q outputs are not valid and should be ignored.

As shown in Table 1-43, shown on Page 1-34, the duty cycle of the EXT_IQ_DAV signal varies from 100% at the widest SPAN values to a very small percentage at the narrowest SPAN values. At a SPAN of 100 Hz, the duty cycle will be 0.00038%; here, the EXT_IQ_DAV signal is active (high) for 20 ns, and then inactive (low) for ≈ 5.28 ms.

The length of time that the EXT_IQ_DAV signal is inactive can be used to determine if the RSA6100A is performing an alignment or a control change. If the EXT_IQ_DAV signal is inactive for longer than 10 ms, then the RSA6100A digital I/Q output data stream has been interrupted.

External equipment used to detect the occurrence of a data interruption can monitor the state of the EXT_IQ_DAV signal. If the EXT_IQ_DAV signal is inactive for 10 ms or more, an alignment or control change has occurred. The duration of the data interruption can be determined by measuring the time between successive EXT_IQ_DAV pulses.



Performance Verification

Performance Verification

Prerequisites

The tests in this section make up an extensive, valid confirmation of performance and functionality when the following requirements are met:

- The cabinet must be installed on the instrument.
- The instrument must have passed the Power On Self Tests (POST).
- The instrument must have been last adjusted at an ambient temperature between +18 °C (+64 °F) and +28 °C (+82 °F), must have been operating for a warm-up period of at least 20 minutes after starting the RSA6100A application, and must be operating at an ambient temperature as listed in Table 1-38.

Required Equipment

The procedures, starting on page 2-5, use external, traceable signal sources to directly check warranted characteristics. Table 2-1 lists the equipment required for this procedure.

Table 2-1: Equipment required for Performance Verification

Item number and description	Minimum requirements	Example	Purpose
1. Frequency Counter	Frequency Range: 10 MHz; Accuracy: 1×10^{-9}	Agilent 53132A Option 10	Checking reference output frequency accuracy
2. RF Power Meter		Agilent E4418B	Adjusting signal generator output level, checking reference output power level
3. RF Power Sensor	10 MHz to 20 GHz RF Flatness: <3% Calibration factor data uncertainty: <2% (RSS)	Agilent E9304A Option H18	
4. Signal Generator	Frequency Accuracy: $\pm 3 \times 10^{-7}$ Output Frequency: 0 to 20 GHz	Anritsu MG3692B Options 2A, 3A, 4, 15A, 16, 22, SM5821	Checking RF flatness, intermodulation distortion, image suppression, and external reference lock check.
5. RF Signal Generator	Output Frequency 0 to 14 GHz Phase Noise at Center Frequency = 1 GHz SSB Phase Noise Offset (F) dBc/Hz 10 Hz -71 100 Hz -93 1 kHz -118 10 kHz -121 100 kHz -119 1 MHz -138	Anritsu MG3692B Options 2A, 3A, 4, 15A, 16, 22, SM5821	Checking phase noise and intermodulation distortion
6. Precision Attenuator	30 dB		
7. Network Analyzer	10 MHz to 3 GHz 10 MHz to 14 GHz	Agilent 8757D	Checking VSWR
8. Power Splitter		Agilent 11667A	Adjusting signal generator output level
9. Power Combiner	Range: 0 to 14 GHz Isolation: >18 dB Insertion loss: 6 dB 3 dB = 2200 MHz	Agilent 11667A with attenuators	Checking intermodulation distortion
10. Low Pass Filters (2)	< 3 dB loss DC - 3 GHz >50 dB rejection 4 GHz to 14 GHz		Checking intermodulation
11. Voltmeter	Capable of measuring 30 VDC	Standard Equipment	Checking Noise Source

Table 2-1: Equipment required for Performance Verification (Cont.)

Item number and description	Minimum requirements	Example	Purpose
12. BNC Cable	50 Ω , 36 in. male to male BNC connectors	Tektronix part number 011-0049-01	Signal interconnection
13. N-N Cable	50 Ω , 36 in. male to male N connectors		Signal interconnection
14. N-SMA Cable	50 Ω , 36 in. male N to male SMA connectors		Signal interconnection
15. Termination, Precision 50 Ω	Impedance: 50 Ω Type N male		Signal termination
16. N-Female to BNC male Adapter		Tektronix part number 103-0058-00	N cable to RSA6100A connections

Preliminary Checks

These steps should be performed before proceeding to the Warranted Characteristics tests.

Fan Check

Plug in the RSA6100A, power it on, and check that the fans located on the left side of the RSA6100A are operating.



CAUTION. Turn the RSA6100A off immediately if the fans are not operating. Operating the spectrum analyzer without fans will damage the instrument.

Warm-up

Make sure the RSA6100A application is running, and allow the instrument to warm up for at least 20 minutes.

NOTE. The fans will slow down and be quieter when the application is started; this is normal. Fan speed may vary while the application is running, depending on the internal temperature detected by the instrument.

CD Drive Check

Press the button on the DVD-R/W drive (Option 07 only) and verify that the tray door opens. Press the button again to close it.

Touch Screen Check

Check that the touch screen detects touches:

1. Verify that the touch screen is enabled (**Touch Screen Off** button is not lighted).
2. Use your finger or a stylus to touch several of the on-screen touchable readouts, such as RBW or Span, and verify they become active when touched.

Power-On Self Tests

Verify that all Power-On Self Tests (POST) passed:

1. Open the Diagnostics page by selecting **Diagnostics** in the **Tools** menu.
2. Select the **Power-On Self Tests** tab, and check that all tests passed.

Diagnostics

Run a complete Diagnostics test session:

1. Select the **Diagnostics** tab.
2. Select the **All Modules, All Tests** checkbox at the top of the list.
3. Touch the **RUN** button. The diagnostics tests will take some time to complete, and some of them are interactive:
 - a. Noise Source Drive 28VDC Out diagnostic will ask you to test the noise source output on the RSA6100A rear-panel.
 - Check with a voltmeter that the voltage is $28\text{ V} \pm 1\text{ V}$.
 - b. The LED Check diagnostic will ask you to verify that all the highlighted LEDs are turned on:
 - Compare the LEDs highlighted in the diagnostic display with the buttons on the front panel.
 - Press each of the keys and rotate the knob on the front panel. You should see the corresponding key in the diagnostic display turn green. Verify that each key is recognized.
 - Click the PASS or FAIL button when done.
 - c. The Display Pixel Test will ask you to look for video problems on the test patterns:
 - Check the Green screen for any stuck or missing pixels. Any keypress, click, or touch will move to the next screen.
 - Repeat with the Red screen, the Blue Screen, and the Gray scale screen. Select Yes or No when the LCD Test dialog asks “Did you see any video problems”.

4. When all diagnostics tests have completed, check that there is a check mark beside each diagnostic name. An X instead of a check mark indicates that the diagnostic had a failure.
5. Click the **Diagnostics Failure** Info tab and verify there is no failure information listed.
6. Click the **Exit Diagnostics** button to exit diagnostics.

Alignment You should align the instrument before proceeding with the Warranted Characteristics tests.

1. Select **Alignments** in the **Tools** menu. The Alignments dialog box will open.
2. Select **Align Now**. The alignment process will take a few minutes.
3. Verify that no alignment failures are reported in the status bar.

Warranted Characteristics tests

The following procedures verify the RSA6100A Series Spectrum Analyzer performance is within the warranted specifications.

Frequency Accuracy

Check Reference Output Frequency Accuracy

1. Connect **REF OUT** on the RSA6100A rear-panel through a 50 Ω precision coaxial cable to the frequency counter input. See Figure 2-1.
2. Connect a precision frequency reference to the frequency counter.

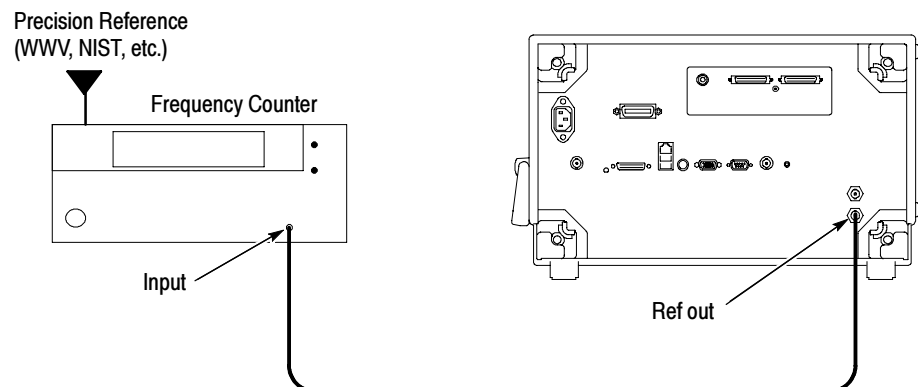

Figure 2-1: Connections for Reference Frequency Output Accuracy check

3. Set the Frequency counter:
Function Frequency
Gate time 2 s
4. **Check** that the frequency counter reads 10 MHz \pm 3 Hz. Enter the frequency in the test record.

Check Reference Output Power Level

1. Set up the power meter and sensor.

NOTE. Store the power sensor correction factors in the power meter, if you have not yet done so.

- a. Connect the power sensor to the Sensor input on the power meter, as shown in Figure 2-2.

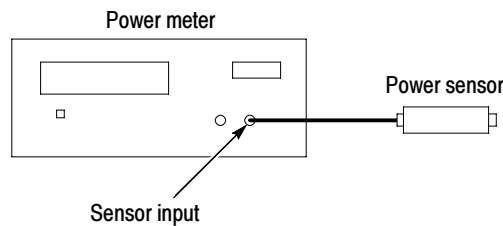

Figure 2-2: Power meter setup

- b. Press **ZERO** on the power meter.
- c. Connect the RF input of the power sensor to the power meter power reference output, as shown in Figure 2-3.

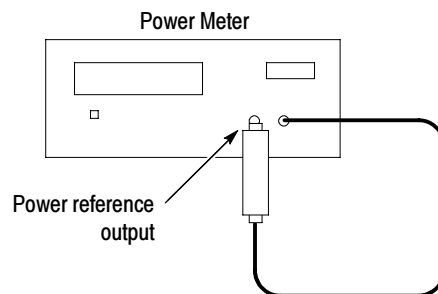

Figure 2-3: Power meter calibration

- d. Turn on **POWER REF** and execute the calibration.

- e. Disconnect the RF input of the power sensor from the power meter reference output.
2. Connect the power sensor RF input to the Ref Out connector on the RSA6100A rear-panel, using the N-female to BNC male adapter (see Figure 2-4).
3. **Check** that the Ref Out signal is >0 dBm. Enter this level in the test record.

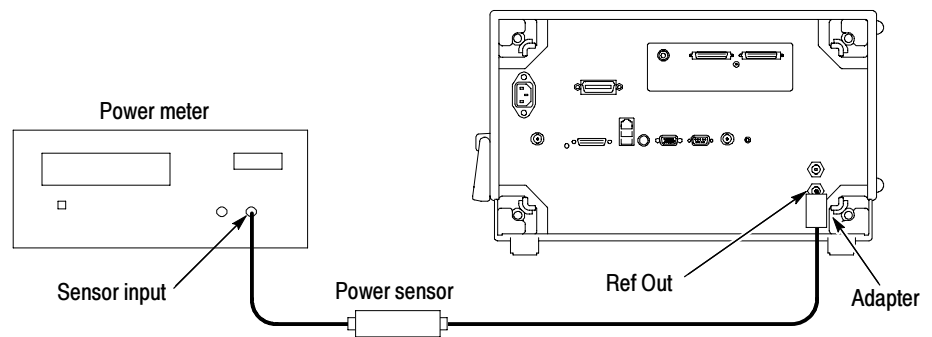

Figure 2-4: Equipment connections for Ref Out power level check

External Reference Input Level

1. Connect the signal generator output to the **Ref In** connector on the RSA6100A rear panel, using a 50 Ω N-N coaxial cable and N-female to BNC male adapter (see Figure 2-5).

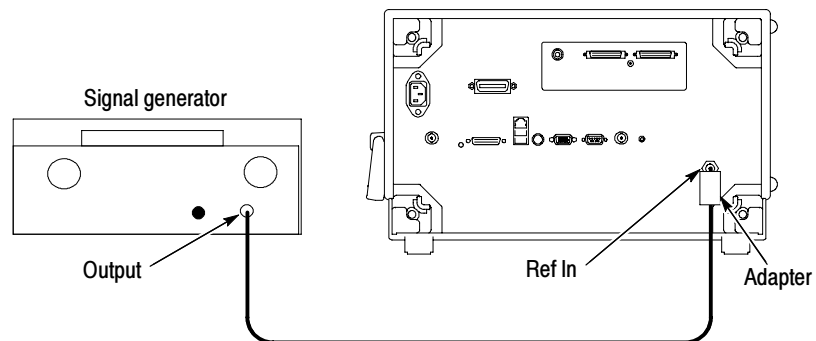

Figure 2-5: Equipment connections for Ref In power level check

2. Set the Signal generator controls:

Frequency	10 MHz
Level	0 dBm

3. Set the RSA6100A to use the external reference:
 - a. Select **Configure In/Out** in the **Setup** menu.
 - b. Select the **Frequency Reference** tab.
 - c. Select the **External** radio button.
4. Check the Input Reference limits:
 - a. Check that the Status Bar shows **Ref: Ext**.
 - b. Set the **Source** to **Internal (10 MHz)**.
 - c. Set the signal generator output level to -10 dBm.
 - d. Set the **Source** to **External**.
 - e. Check that the Status Bar shows **Ref: Ext**.
 - f. Set the **Source** to **Internal (10 MHz)**.
 - g. Set the signal generator output level to +6 dBm.
 - h. Set the **Source** to **External**.
 - i. Check that the Status Bar shows **Ref: Ext**.
 - j. Disconnect the signal generator from the **Ref In** connector. An error message should pop up to indicate loss of lock (see Figure 2-6).

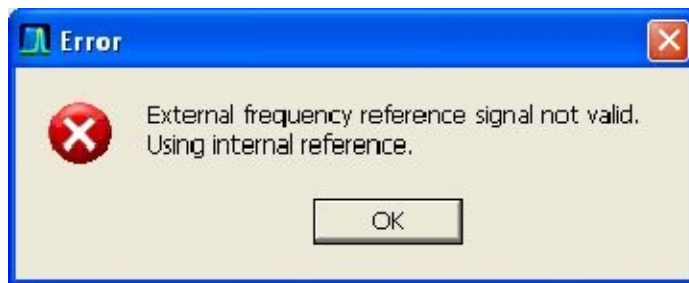

Figure 2-6: Error message showing loss of lock to External Reference signal

- k. Click OK on the error message, and check that the Status Bar shows **Ref: Int**.
- l. Enter Pass or Fail in the test record.

Phase Noise

Check Phase Noise

1. Connect the generator output to the RTSA RF Input, using a 50 Ω N-N coaxial cable (see Figure 2-7).

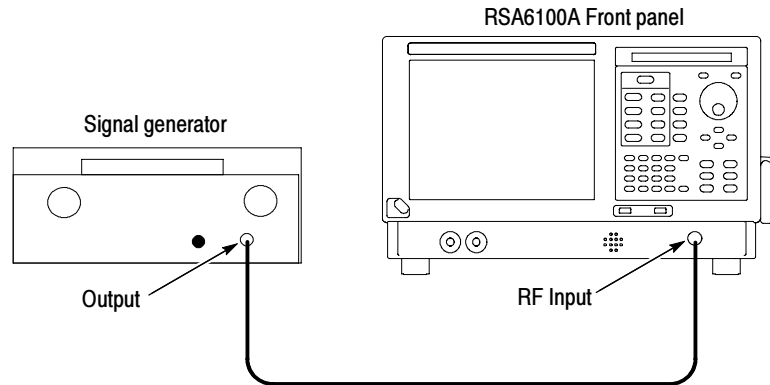

Figure 2-7: Equipment connections for phase noise checks

2. Reset the RSA6100A to factory defaults; by pressing the **Preset** button, or selecting **Preset** from the **Setup** menu.
3. Modify the default settings:

Center Frequency	1000 MHz
Span	100 kHz
Ref Level	5 dBm
RF & IF Optimization	Minimize Noise

 (Settings > BW tab)
4. Set the RSA6100A for a single acquisition:
 - a. Select the **ACQ** soft key.
 - b. Select **Single** from the **Run:** dropdown menu.
5. Select the **Traces** tab in the **Settings** menu and set for 100 averages:

Trace:	Trace 1
Detection:	+Peak
Function:	Average
Averages	100
6. Set the generator controls:

Frequency	1000 MHz
Amplitude	5 dBm
RF output	On

7. Turn on the Reference Marker (MR) and Marker 1 (M1), and set them for Delta operation, and Noise Mode.
 - a. Select **Define Markers** in the **Markers** menu.
 - b. Select the **Add** soft key to add the MR marker.
 - c. Select the **Add** soft key again to add the M1 marker
 - d. Select **Delta** from the **Readouts** dropdown menu.
 - e. Select the **Settings** button, click the **Prefs** tab, and then select the **Marker Noise Mode** checkbox so it is checked.
8. Press **Run**.
9. Select the Reference Marker (MR) with the marker select key and touch the **peak** soft key, to set MR to the carrier peak (1 GHz).
10. Adjust the generator output amplitude so the display on-screen is within 1 dB of the top of the screen.
11. Set the RSA6100A to each of the spans shown in Table 2-2 in turn.

Table 2-2: Phase Noise Offsets (Low Range)

Span	M1 Offset
400 Hz	CF + 100 Hz
4 kHz	CF + 1 kHz
40 kHz	CF + 10 kHz
400 kHz	CF + 100 kHz

12. Repeat these steps for each span setting:
 - a. Press **Run**.
 - b. Select the Reference Marker with the marker select key and press the **Peak** key.
 - c. Select Marker 1 (M1) with the marker select key.
 - d. Set Marker 1 (M1) using the rotary knob to the offset frequency shown in Table 2-2. The offset frequency is indicated by the M1 Delta Marker readout.
 - e. Read the noise level in dBc/Hz, in the Delta Marker readout (upper right corner of the screen), and enter the value in the test record. (Limits are shown in the test record.)

13. Set the RSA6100A to each of the spans shown in Table 2-3 in turn.

Table 2-3: Phase Noise Offsets (High Range)

Span	M1 Offset
4 MHz	CF + 1 MHz
24 MHz	CF + 6 MHz
40 MHz	CF + 10 MHz

14. Repeat these steps for each span setting:

- a. Press **Run**.
- b. Select the Reference Marker with the marker select key and press the Peak key.
- c. Select Marker 1 (M1) with the marker select key.
- d. Set M1 to the offset frequency shown in Table 2-3.
- e. Select the **Ampl** softkey, select the **Manual** radio button, and set the **Internal attenuator** to 25 dB.
- f. Press **Run**.
- g. Check for an ADC Overrange message in the bottom edge of the display.
- h. Reduce the Internal attenuator level by 5 dB.
- i. Press **Run**.
- j. Repeat parts g, h, and i until an ADC Overrange is detected, or the Internal attenuator level is 0 dB.
- k. If an ADC Overrange is detected, increase the Internal attenuator level by 5 dB, otherwise leave the attenuator level at 0 dB.
- l. Press **Run**.
- m. Read the noise level in dBc/Hz, in the Delta Marker readout (upper right corner of the screen), and enter the value in the test record. (Limits are shown in the test record.)

RF Input

- Input VSWR (Preamp OFF)** 1. Connect the RSA6100A and the Network Analyzer as shown in Figure 2-8.

NOTE. Verify that the network analyzer is properly calibrated, as specified by the manufacturer, before taking measurements on the RSA6100A.

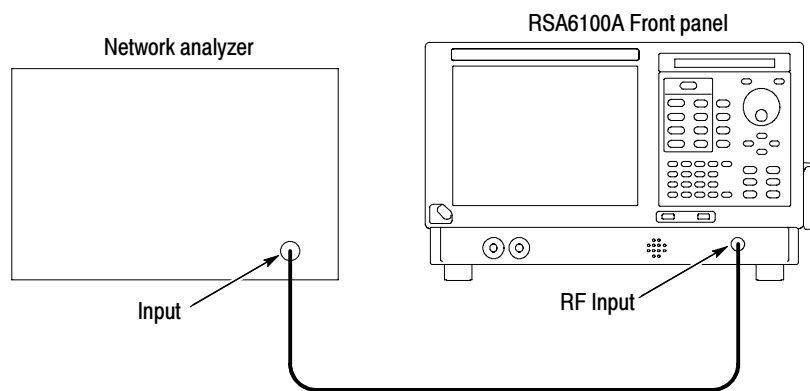

Figure 2- 8: Equipment connections for VSWR check

2. Reset the RSA6100A to factory defaults; by pressing the **Preset** button, or selecting **Preset** from the **Setup** menu.
3. Select the **Ampl** softkey, select the **Manual** radio button, and set the **Internal attenuator** to 10 dB.
4. Set the START/STOP frequency of the Network Analyzer to 10 MHz/4 GHz.
5. Set the Center Frequency to ± 200 MHz of the Network Analyzer frequency to be measured.
6. Change the Center frequency from 10 MHz to 4 GHz by 400 MHz steps.
7. **CHECK** that the VSWR of the RSA6100A is < 1.6 for frequencies from 10 MHz to 4 GHz, making sure that the RSA6100A center frequency and the Network Analyzer frequency remain within ± 200 MHz of each other. Enter the highest VSWR in the test record. (Limits are shown in the test record.)
8. Set the START/STOP frequency of the Network Analyzer to 4 GHz/6.2 GHz and change the center frequency of the RSA6100A from 4 GHz to 6.2 GHz by 400 MHz steps.

9. **CHECK** that the VSWR of the RSA6100A is <1.8 for frequencies from 4 GHz to 6.2 GHz, making sure that the RSA6100A center frequency and the Network Analyzer frequency remain within ± 200 MHz of each other. Enter the highest VSWR in the test record. (Limits are shown in the test record.)
10. Set the START/STOP frequency of the Network Analyzer to 6.2 GHz/14 GHz and change the center frequency of the RSA6100A from 6.2 GHz to 14 GHz by 400 MHz steps.
11. **CHECK** (RSA6114A only) that the VSWR of the RSA6100A is <1.9 for frequencies from 6.2 GHz to 14 GHz, making sure that the RSA6100A center frequency and the Network Analyzer frequency remain within ± 200 MHz of each other. Enter the highest VSWR in the test record. (Limits are shown in the test record.)

Input VSWR (Preamp ON - Option 01 Only)

1. Turn the Preamp on.

NOTE. *Preamp control is located on the Amplitude menu.*

2. Set the RSA6100A Center frequency to 1.5 GHz.
3. Set the Network Analyzer span to 10 MHz to 3.0 GHz.
4. **CHECK** that the VSWR of the RSA6100A is <1.9 across the entire frequency span. Enter the maximum VSWR in the test record. (Limits are shown in the test record.)

Amplitude

RF Flatness (Frequency Response) 10 MHz to 14 GHz

1. Connect the RF generator, power splitter, power meter, and RSA6100A, as shown in Figure 2-9. The 30 dB attenuator is only used when testing Option 01, with the preamp ON.

The power splitter outputs should connect directly to the RSA6100A RF Input (or the 30 dB attenuator) and to the Power Sensor, without using cables.

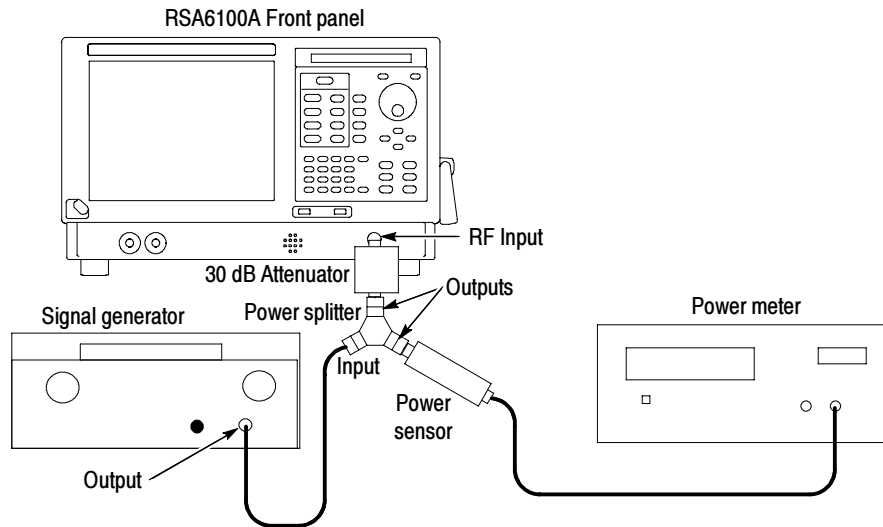

Figure 2-9: Equipment connections for RF Flatness check

2. Print out the pages containing Table 2-4, to record the test readings.
3. Reset the RSA6100A to factory defaults; by pressing the **Preset** button, or selecting **Preset** from the **Setup** menu.
4. Set the RSA6100A Attenuator level to 10 dB:
 - a. Select **Amplitude** from the **Setup** menu.
 - b. Click the **Manual** radio button in the **Internal attenuator** section.
 - c. Set the attenuator to 10 dB.
5. Select the **Traces** tab in the **Settings** menu and set for 10 averages:

Trace:	Trace 1
Detection:	+Peak
Function:	Average
Averages	10
6. Set the Option 01 Preamp OFF (if installed).
7. Set the RF generator for a -15 dBm output amplitude.
8. Set both the RF generator output frequency and the RSA6100A Center Frequency to 100 MHz. This is the reference frequency.
9. Select the **Markers** button, and then select the **Peak** soft key to set the Reference Marker (MR) to the carrier peak.
10. Record the Power Meter reading and the RSA6100A reading in Table 2-4.

11. Set both the RF generator output frequency and the RSA6100A Center Frequency to 10 MHz.
12. Select the **Peak** soft key to set the Reference Marker (MR) to the carrier peak.
13. Record the Power Meter reading and the RSA6100A reading in Table 2-4.
14. Calculate the Δ Power Meter number: subtract the Power Meter reading at 100 MHz from the Power Meter reading at this frequency.
15. Calculate the Δ RTSA number: subtract the RTSA reading at 100 MHz from the RTSA reading at this frequency.
16. Calculate the RF Flatness Error:

$$RF\ Flatness\ Error = \Delta\ RTSA\ at\ this\ freq - \Delta\ Power\ Meter\ at\ this\ freq$$

Readings are in dBm, error is in dB.
17. Repeat parts 11 through 16 for each of the center frequencies shown in Table 2-4.

Table 2-4: RF Flatness (Preamp OFF, if installed)

Attenuator = 10 dB					
Frequency	Power meter reading	Δ Power meter (vs. 100 MHz)	RTSA reading	Δ RTSA reading (vs. 100 MHz)	RF flatness error ²
100 MHz		0		0	0
10 MHz					
20 MHz					
30 MHz					
40 MHz					
50 MHz					
60 MHz					
70 MHz					
80 MHz					
90 MHz					
200 MHz					
300 MHz					
400 MHz					
500 MHz					
600 MHz					
700 MHz					
800 MHz					

Table 2-4: RF Flatness (Preamp OFF, if installed) (Cont.)

Attenuator = 10 dB					
Frequency	Power meter reading	Δ Power meter (vs. 100 MHz)	RTSA reading	Δ RTSA reading (vs. 100 MHz)	RF flatness error ²
900 MHz					
1.0 GHz					
1.1 GHz					
1.2 GHz					
1.3 GHz					
1.4 GHz					
1.5 GHz					
1.6 GHz					
1.7 GHz					
1.8 GHz					
1.9 GHz					
2.0 GHz					
2.1 GHz					
2.2 GHz					
2.3 GHz					
2.4 GHz					
2.5 GHz					
2.6 GHz					
2.7 GHz					
2.8 GHz					
2.9 GHz					
3.0 GHz					
3.1 GHz					
3.2 GHz					
3.3 GHz					
3.4 GHz					
3.5 GHz					
3.6 GHz					
3.7 GHz					
3.8 GHz					
3.9 GHz					
4.0 GHz					
4.1 GHz					

Table 2-4: RF Flatness (Preamp OFF, if installed) (Cont.)

Attenuator = 10 dB					
Frequency	Power meter reading	Δ Power meter (vs. 100 MHz)	RTSA reading	Δ RTSA reading (vs. 100 MHz)	RF flatness error ²
4.2 GHz					
4.3 GHz					
4.4 GHz					
4.5 GHz					
4.6 GHz					
4.7 GHz					
4.8 GHz					
4.9 GHz					
5.0 GHz					
5.1 GHz					
5.2 GHz					
5.3 GHz					
5.4 GHz					
5.5 GHz					
5.6 GHz					
5.7 GHz					
5.8 GHz					
5.9 GHz					
6.0 GHz					
6.1 GHz					
6.2 GHz					
RSA6114A only					
6.3 GHz					
6.4 GHz					
6.5 GHz					
6.6 GHz					
6.7 GHz					
6.8 GHz					
6.9 GHz					
7.0 GHz					
7.1 GHz					
7.2 GHz					
7.3 GHz					

Table 2-4: RF Flatness (Preamp OFF, if installed) (Cont.)

Attenuator = 10 dB					
Frequency	Power meter reading	Δ Power meter (vs. 100 MHz)	RTSA reading	Δ RTSA reading (vs. 100 MHz)	RF flatness error ²
7.4 GHz					
7.5 GHz					
7.6 GHz					
7.7 GHz					
7.8 GHz					
7.9 GHz					
8.0 GHz					
8.1 GHz					
8.2 GHz					
8.3 GHz					
8.4 GHz					
8.5 GHz					
8.6 GHz					
8.7 GHz					
8.8 GHz					
8.9 GHz					
9.0 GHz					
9.1 GHz					
9.2 GHz					
9.3 GHz					
9.4 GHz					
9.5 GHz					
9.6 GHz					
9.7 GHz					
9.8 GHz					
9.9 GHz					
10.0 GHz					
10.1 GHz					
10.2 GHz					
10.3 GHz					
10.4 GHz					
10.5 GHz					
10.6 GHz					

Table 2-4: RF Flatness (Preamp OFF, if installed) (Cont.)

Attenuator = 10 dB					
Frequency	Power meter reading	Δ Power meter (vs. 100 MHz)	RTSA reading	Δ RTSA reading (vs. 100 MHz)	RF flatness error ²
10.7 GHz					
10.8 GHz					
10.9 GHz					
11.0 GHz					
11.1 GHz					
11.2 GHz					
11.3 GHz					
11.4 GHz					
11.5 GHz					
11.6 GHz					
11.7 GHz					
11.8 GHz					
11.9 GHz					
12.0 GHz					
12.1 GHz					
12.2 GHz					
12.3 GHz					
12.4 GHz					
12.5 GHz					
12.6 GHz					
12.7 GHz					
12.8 GHz					
12.9 GHz					
13.0 GHz					
13.1 GHz					
13.2 GHz					
13.3 GHz					
13.4 GHz					
13.5 GHz					
13.6 GHz					
13.7 GHz					
13.8 GHz					
13.9 GHz					

Table 2-4: RF Flatness (Preamp OFF, if installed) (Cont.)

Attenuator = 10 dB					
Frequency	Power meter reading	Δ Power meter (vs. 100 MHz)	RTSA reading	Δ RTSA reading (vs. 100 MHz)	RF flatness error ²
14.0 GHz					

² Use the formula on page 2-15

18. For spectrum analyzers with Option 01 installed, add the precision 30 dB attenuator as shown in Figure 2-9 and repeat this process for the range of 10 MHz to 3 GHz with the Preamp ON.

Table 2-5: RF Flatness (Option 01 Preamp ON)

Attenuator = 10 dB					
Frequency	Power meter reading	Δ Power meter (vs. 100 MHz)	RTSA reading	Δ RTSA reading (vs. 100 MHz)	RF flatness error ²
100 MHz		0		0	0
10 MHz					
20 MHz					
30 MHz					
40 MHz					
50 MHz					
60 MHz					
70 MHz					
80 MHz					
90 MHz					
200 MHz					
300 MHz					
400 MHz					
500 MHz					
600 MHz					
700 MHz					
800 MHz					
900 MHz					
1.0 GHz					
1.1 GHz					
1.2 GHz					
1.3 GHz					

Table 2-5: RF Flatness (Option 01 Preamp ON) (Cont.)

Attenuator = 10 dB					
Frequency	Power meter reading	Δ Power meter (vs. 100 MHz)	RTSA reading	Δ RTSA reading (vs. 100 MHz)	RF flatness error ²
1.4 GHz					
1.5 GHz					
1.6 GHz					
1.7 GHz					
1.8 GHz					
1.9 GHz					
2.0 GHz					
2.1 GHz					
2.2 GHz					
2.3 GHz					
2.4 GHz					
2.5 GHz					
2.6 GHz					
2.7 GHz					
2.8 GHz					
2.9 GHz					
3.0 GHz					

² Use the formula on page 2-15

19. Enter the largest variation in each of the following frequency ranges into the test record:

- 10 MHz - 3 GHz (Preamp OFF)
- 10 MHz - 3 GHz (Preamp ON, Option 01 only)
- 3 GHz - 6.2 GHz
- 6.2 GHz - 14 GHz (RSA6114A only)

Absolute Accuracy at Calibration Point

1. Connect the RF generator, power splitter, power meter, and RSA6100A, as shown in Figure 2-9.
2. Reset the RSA6100A to factory defaults by pressing the **Preset** button, or selecting **Preset** from the **Setup** menu.
3. Set the RSA6100A:
Reference Level -20 dBm

Center Frequency 100 MHz
Span 1 MHz

4. Set the RF Generator:
Output Frequency 100 MHz
Output Level -14 dBm
5. Align the RSA6100A:
 - a. Select **Alignments** in the **Tools** menu.
 - b. Click the **Align Now** button.
6. Select the **Markers** button, and then select the **Peak** soft key to set the Reference Marker (MR) to the carrier peak.
7. Record the reading on the Power Meter and on the RSA6100A.
8. Calculate the Absolute Amplitude Error:
 $Error = RSA6100A\ reading - Power\ Meter\ reading$
Readings are in dBm, error is in dB.
9. Record the Absolute Amplitude Error in the test record. (Limits are shown in the test record.)

Noise and Distortion

Third Order Intermodulation Distortion

1. Set up the RF sinewave generators, Lowpass filters, Signal Combiner, and RSA6100A, as shown in Figure 2-10.

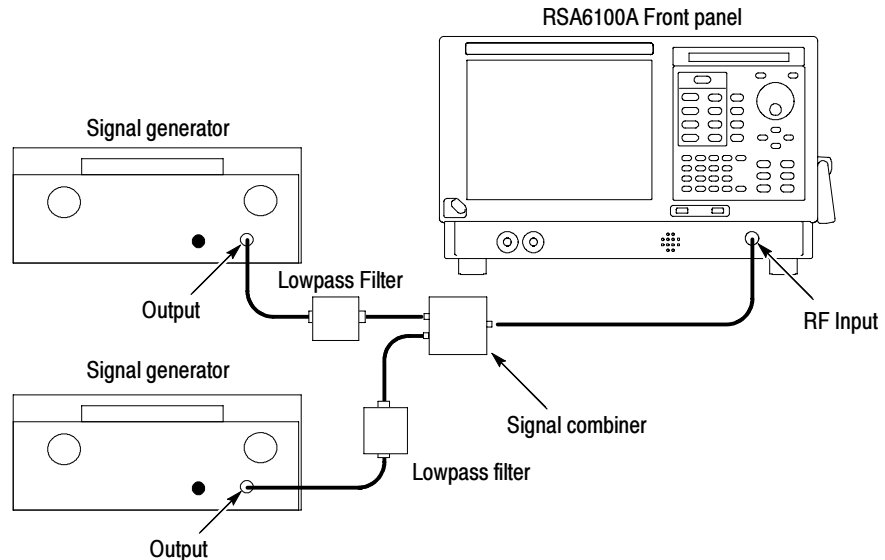

Figure 2-10: Equipment connections for Third Order Intermodulation Distortion check

2. Set the RSA6100A:

Reference Level	-20 dBm
Span	10 kHz
RBW	Auto
Attenuator	0 dB
Preamp	OFF (Option 01 only)
Averaging	10
3. Select the **Settings** button, and then the **BW** tab.
4. Select **Maximum Dynamic Range** in the **RF & IF Optimization** dropdown menu.
5. Set each of the two generators to provide a power level of -28 dBm. The tones must be of equal amplitude.
 - a. Set the first generator output frequency to 2.1295 GHz, and the second generator output frequency to 2.1305 GHz.

- b. Set the RSA6100A Center frequency to 2.1295 GHz and use the peak marker readout to set the first generator output level to -25.0 dBm on the display.
 - c. Set the RSA6100A Center frequency to 2.1305 GHz and use the peak marker readout to set the second generator output level to -25.0 dBm on the display.
6. Set the RTSA center frequency to 2.1285 GHz and use an amplitude marker to read the amplitude level of the signal displayed at the center of the screen. Note this amplitude.
 7. Set the RTSA center frequency to 2.1315 GHz and use an amplitude marker to read the amplitude level of the signal displayed at the center of the screen. Note this amplitude.
 8. Record the higher of these two center frequency readings in the test record. It should be <-80 dBc against the carrier signal. It should be approximately -105 dBm or less of the absolute power readings on the screen.

DANL - Preamp OFF

1. Terminate the RSA6100A RF Input with a 50 Ω terminator.
2. Reset the RSA6100A to factory defaults by pressing the **Preset** button, or selecting **Preset** from the **Setup** menu.
3. Set the RSA6100A:
 - Reference Level -50 dBm
 - Center Frequency 9 kHz
 - Span 100 kHz
 - RBW 1 kHz
 - Averages 100
 - Attenuator 0 dB
 - Preamp (Option 01 only) OFF
4. Set the markers for Noise Mode operation:
 - a. Select the **Markers** button or soft key.
 - b. Select the **Define** soft key.
 - c. Select the **Add** soft key to add the Reference marker (MR).
 - d. Set the Reference marker to 0 Hz.
 - e. Select the **Add** soft key again to add Marker 1 (M1).
 - f. Select the **Settings** button, click the **Prefs** tab, and then select the **Marker Noise Mode** checkbox so it is checked.

5. Set the RSA6100A to each of the Center Frequencies listed in table 2-6 in turn, and use Marker 1 to measure the noise level at the center frequency, in dBm/Hz (Absolute readout).

NOTE. *The intent of the DANL test is to measure the average internal noise level of the instrument. The DANL specification does not cover residual spurs. If the specific measurement frequency results in measuring a residual spur that is visible above the noise level, the DANL specification applies not to the spur but to the noise level on either side of the spur. Please refer to the Spurious Response specifications (Table 1-13 on page 1-11) and to the Spurious Response section of this procedure (see page 2-30) to determine whether or not a residual spur is within the specification.*

Table 2-6: Frequencies of interest for DANL check

Center Frequency	Noise Level	Frequency Range
9 kHz		9 kHz - 10 MHz
9.9 MHz		
10.1 MHz		10 MHz - 100 MHz
99 MHz		
101 MHz		100 MHz - 2.3 GHz
2.29 GHz		
2.31 GHz		2.3 GHz - 4.0 GHz
3.99 GHz		
4.01 GHz		4.0 GHz - 6.2 GHz
6.2 GHz		
6.21 GHz		6.2 GHz - 7.0 GHz (RSA6114A only)
6.99 GHz		
7.01 GHz		7.0 GHz - 14.0 GHz (RSA6114A only)
8.0 GHz		
9.0 GHz		
10.0 GHz		
11.0 GHz		
12.0 GHz		
13.0 GHz		
14.0 GHz		

6. Enter the highest noise level for each of the frequency ranges shown into the test record. (Limits are shown in the test record.)

**DANL - Preamp ON
(Option 01 Only)**

1. Continuing from the previous step, change the RSA6100A settings:
Reference Level -70 dBm
Preamp ON
2. Use Marker 1 to measure the noise level, in dBm/Hz (Absolute readout), at each of the Center Frequencies shown in Table 2-7:

Table 2-7: Frequencies of interest for DANL check (Option 01)

Center Frequency	Noise Level	Frequency Range
10 MHz		10 MHz - 50 MHz
49 MHz		
51 MHz		50 MHz - 1 GHz
990 MHz		
1.01 GHz		1 GHz - 2 GHz
1.99 GHz		
2.01 GHz		2 GHz - 3 GHz
3 GHz		

3. Enter the highest noise level for each of the frequency ranges shown into the test record. (Limits are shown in the test record.)

IF Flatness (Channel Response)

1. Connect the RF generator, power splitter, power meter, and RSA6100A as shown in Figure 2-11.

The power splitter outputs should connect directly to the RSA6100A RF Input and to the Power Sensor.

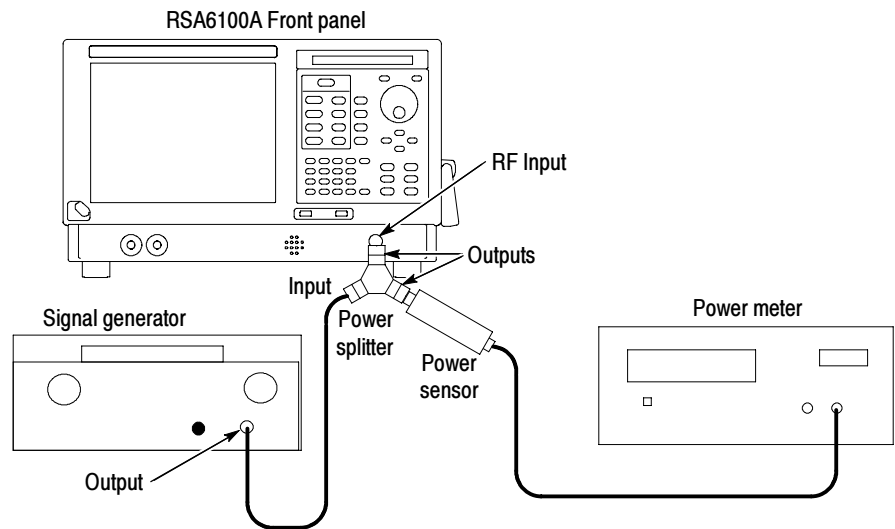

Figure 2- 11: Equipment connections for IF Flatness check

2. Reset the RSA6100A to factory defaults; by pressing the **Preset** button, or selecting **Preset** from the **Setup** menu.
3. Set the RSA6100A:
 - Span 300 kHz
 - Reference Level 0 dBm
4. Set both the RF generator output frequency and the RSA6100A Center Frequency to 200 MHz. This is the reference frequency.
5. Select the **Markers** button and then select the **Peak** soft key to set the Reference marker to the carrier peak.
6. Set the signal generator output level to -10 dBm \pm 1 dBm, shown on the RSA6100A display.
7. Record the Power Meter reading and the RSA6100A marker reading in Table 2-8.
8. Set the RF generator output frequency to 199.85 MHz.
9. Leave the RSA6100A center frequency at 200 MHz and use the Reference marker to measure the amplitude at this new frequency.
10. Record the Power Meter reading and the RSA6100A reading in Table 2-8.
11. Calculate the Δ Power Meter number: subtract the Power Meter reading at 200 MHz from the Power Meter reading at this frequency.
12. Calculate the Δ RTSA number: subtract the RSA6100A reading at 200 MHz from the RSA6100A reading at this frequency.

13. Calculate the IF Flatness Error using the formula:
 $RF \text{ Flatness Error} = \Delta \text{ RTSA at this freq} - \Delta \text{ Power Meter at this freq}$

Readings are in dBm, error is in dB.

14. Repeat parts 8 through 13 for each of the remaining generator frequencies shown in the Span = 300 kHz portion of Table 2-8.
15. Record the highest Calculated IF Flatness Error for the Span setting into the test record. (Limits are shown in the test record.)
16. Repeat this process for Span settings of 10 MHz, 20 MHz, and 40 MHz, using the appropriate span segment of Table 2-8.
17. (Option 110 only.) Repeat this process for a 110 MHz Span setting.

Table 2-8: IF Flatness

Generator Frequency	Power meter reading	Δ Power meter (vs. 200 MHz)	RTSA reading	Δ RTSA reading (vs. 200 MHz)	Calculated IF Flatness Error
Span = 300 kHz					
200 MHz		0		0	0
199.85 MHz					
199.88 MHz					
199.91 MHz					
199.94 MHz					
199.97 MHz					
200.03 MHz					
200.06 MHz					
200.09 MHz					
200.12 MHz					
200.15 MHz					
Span = 10 MHz					
200 MHz		0		0	0
195 MHz					
196 MHz					
197 MHz					
198 MHz					
199 MHz					
201 MHz					
202 MHz					
203 MHz					

Table 2-8: IF Flatness (Cont.)

Generator Frequency	Power meter reading	Δ Power meter (vs. 200 MHz)	RTSA reading	Δ RTSA reading (vs. 200 MHz)	Calculated IF Flatness Error
Span = 10 MHz					
204 MHz					
205 MHz					
Span = 20 MHz					
200 MHz		0		0	0
190 MHz					
192 MHz					
194 MHz					
196 MHz					
198 MHz					
202 MHz					
204 MHz					
206 MHz					
208 MHz					
210 MHz					
Span = 40 MHz					
200 MHz		0		0	0
180 MHz					
184 MHz					
188 MHz					
192 MHz					
196 MHz					
204 MHz					
208 MHz					
212 MHz					
216 MHz					
220 MHz					
Span = 110 MHz (Option 110 only)					
200 MHz		0		0	0
145 MHz					
156 MHz					
167 MHz					
178 MHz					

Table 2-8: IF Flatness (Cont.)

Generator Frequency	Power meter reading	Δ Power meter (vs. 200 MHz)	RTSA reading	Δ RTSA reading (vs. 200 MHz)	Calculated IF Flatness Error
Span = 110 MHz (Option 110 only)					
189 MHz					
211 MHz					
222 MHz					
233 MHz					
244 MHz					
255 MHz					

Spurious Response

Residual Response

1. Terminate the RSA6100A RF Input.
2. Reset the RSA6100A to factory defaults; by pressing the **Preset** button, or selecting **Preset** from the **Setup** menu.
3. Set the RSA6100A:
 - Center Frequency See Table 2-9
 - Reference Level -30 dBm
 - Span 40 MHz
 - RBW 1 kHz
 - Averages 50
4. Note the maximum signal level across the span for each of the center frequencies shown in Table 2-9, from 200 MHz to 6.2 GHz.
5. Enter the highest of these signal levels into the test record.

Table 2-9: Residual Response Center Frequencies

MHz	GHz	GHz	GHz	GHz
200	1.44	2.68	3.92	5.16
240	1.48	2.72	3.96	5.20
280	1.52	2.76	4.00	5.24
320	1.56	2.80	4.04	5.28
360	1.6	2.84	4.08	5.32
400	1.64	2.88	4.12	5.36
440	1.68	2.92	4.16	5.40

Table 2-9: Residual Response Center Frequencies (Cont.)

MHz	GHz	GHz	GHz	GHz
480	1.72	2.96	4.20	5.44
520	1.76	3.00	4.24	5.48
560	1.8	3.04	4.28	5.52
600	1.84	3.08	4.32	5.56
640	1.88	3.12	4.36	5.60
680	1.92	3.16	4.40	5.64
720	1.96	3.20	4.44	5.68
760	2.0	3.24	4.48	5.72
800	2.04	3.28	4.52	5.76
840	2.08	3.32	4.56	5.80
880	2.12	3.36	4.60	5.84
920	2.16	3.40	4.64	5.88
960	2.20	3.44	4.68	5.92
1000	2.24	3.48	4.72	5.96
1040	2.28	3.52	4.76	6.00
1080	2.32	3.56	4.80	6.04
1120	2.36	3.60	4.84	6.08
1160	2.40	3.64	4.88	6.12
1200	2.44	3.68	4.92	6.16
1240	2.48	3.72	4.96	6.20
1280	2.52	3.76	5.00	-- --
1320	2.56	3.80	5.04	-- --
1360	2.60	3.84	5.08	-- --
1400	2.64	3.88	5.12	-- --

Image Suppression

1. Connect the RF generator capable of at least 20 GHz to the RSA6100A RF Input, as shown in Figure 2-12.
2. Reset the RSA6100A to factory defaults; by pressing the **Preset** button, or selecting **Preset** from the **Setup** menu.

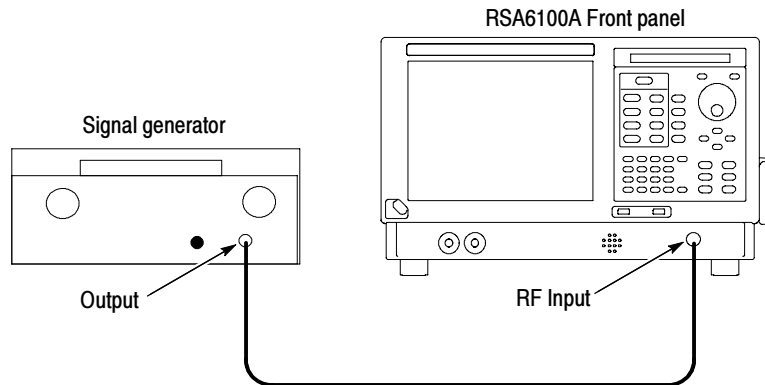

Figure 2- 12: Equipment connections for Image Suppression check

3. Set the RSA6100A:
 - Reference Level -30 dBm
 - Attenuator 10 dB
 - Span 100 kHz
 - RBW 10 Hz
 - Averages 50
4. Set the RF generator: Output Level to -30 dBm at the end of the cable. Verify the output level with the power meter, if necessary.

Table 2- 10: Image Suppression Settings

RSA6100A Center Frequency	RF Generator Output Frequency (Image)
All Models	
1 GHz	20 GHz
3.868 GHz	11.434 GHz
RSA6114A only	
8.2 GHz	16.2 GHz
9.1 GHz	17.1 GHz
10 GHz	18 GHz
11 GHz	19 GHz
12 GHz	20 GHz

5. For each row of Table 2-10:
 - a. Set the RSA6100A to the Center Frequency shown in the first column.

- b. Set the RF generator output frequency to the Image Frequency shown in the second column.
- c. Read the signal amplitude, in dBm, at center screen. Subtract -30 dBm from the signal amplitude, to convert it to dBc.
- d. Enter this value in the test record.

Spurious Response with Signal

1. Connect the RF generator to the RSA6100A RF Input, as shown in Figure 2-13.

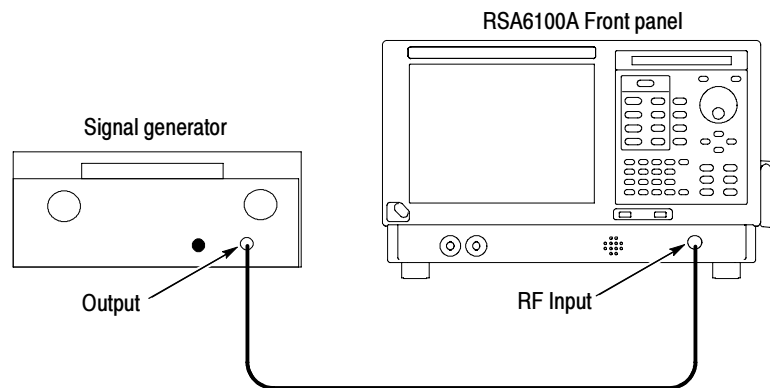

Figure 2-13: Equipment connections for Signal Spurious check

2. Reset the RSA6100A to factory defaults; by pressing the **Preset** button, or selecting **Preset** from the **Setup** menu.
3. Set the RSA6100A:

Center Frequency	1 GHz
Reference Level	-15 dBm
Span	40 MHz
RBW	1 kHz
Attenuator	10 dB
Averages	100
4. Set the RF generator:

Output Level	-15 dBm
Output Frequency	1 GHz
5. Check that all signals within ± 20 MHz of the Center Frequency are < -73 dBc.
6. (Option 110 only) Set the RSA6100A Span to 110 MHz.

7. Check that all signals within ± 55 MHz of the Center Frequency are < -73 dBc.
8. Enter Pass or Fail into the test record.

Spurious Response with Signal (Half-IF)

1. Connect the RF generator to the RSA6100A RF Input, as shown in Figure 2-13.

NOTE. Use a low-pass filter if the RF generator has a 2nd harmonic performance more than 10 dB below the specification being measured.

2. Reset the RSA6100A to factory defaults; by pressing the **Preset** button, or selecting **Preset** from the **Setup** menu.
3. Set the RSA6100A:
 - Center Frequency See Table 2-11
 - Reference Level -30 dBm
 - Span 10 kHz
 - Attenuator 10 dB
 - Averages 100
4. Set the RF generator:
 - Output Level -30 dBm
 - Output Frequency 4.75 GHz
5. Check the signal amplitude, in dBm, at each of the center frequencies shown in Table 2-11. Subtract -30 dBm from the signal amplitude to convert it to dBc.
6. Enter this value in the test record.

Table 2- 11: Center Frequencies for Half-IF

9 kHz	3 GHz	6 GHz
1 GHz	4 GHz	7 GHz (RSA6114A only)
2 GHz	5 GHz	8 GHz (RSA6114A only)

7. Enter the signal amplitude for each center frequency into the test record. (Limits are shown in the test record.)

This ends the Performance Verification procedure.

Test Record

Print out the following test record pages and use them to record the performance test results for your spectrum analyzer.

RSA6100A Series Test Record

Model: _____ Serial Number: _____

Certificate Number: _____ Calibration Date: _____

Technician: _____

Frequency Accuracy	Low limit	Test Result	High limit
Reference output frequency accuracy	9,999,997 Hz		10,000,003 Hz
Reference output power level	0 dBm		
External reference input level	Fail		Pass

Phase Noise	Low limit	Test Result	High limit
Offset			
CF + 100 Hz			-80 dBc/Hz
CF + 1 kHz			-100 dBc/Hz
CF + 10 kHz			-106 dBc/Hz
CF + 100 kHz			-107 dBc/Hz
CF + 1 MHz			-128 dBc/Hz
CF + 6 MHz			-134 dBc/Hz
CF + 10 MHz			-134 dBc/Hz

Input VSWR	Low limit	Test Result	High limit
Preamp OFF			
10 MHz - 4 GHz			1.6
>4 GHz - 6.2 GHz			1.8
>6.2 GHz - 14 GHz (RSA6114A only)			1.9
Preamp ON (Option 01 only)			
10 MHz - 3 GHz			1.9

RF Input Flatness	Low limit	Test Result	High limit
Attenuator = 10 dB			
10 MHz - 3 GHz (Preamp OFF)	-0.5 dB		+0.5 dB
10 MHz - 3 GHz (Preamp ON)	-0.7 dB		+0.7 dB
3 GHz - 6.2 GHz	-0.8 dB		+0.8 dB
6.2 GHz - 14 GHz (RSA6114A only)	-1.0 dB		+1.0 dB

Absolute accuracy at calibration point	Low limit	Test Result	High limit
Absolute amplitude error	-0.31 dB		+0.31 dB

Third Order Intermodulation Distortion	Low limit	Test Result	High limit
2.130 GHz			-80 dBc

Displayed Average Noise Level (DANL)	Low limit	Test Result	High limit
Preamp OFF			
9 kHz - 10 MHz			-97 dBm/Hz
10 MHz - 100 MHz			-147 dBm/Hz
100 MHz - 2.29 GHz			-149 dBm/Hz
2.31 GHz - 3.99 GHz			-147 dBm/Hz
4.01 GHz - 7 GHz			-143 dBm/Hz
7 GHz - 14 GHz (RSA6114A only)			-135 dBm/Hz
Preamp ON (Option 01 only)			
10 MHz - 50 MHz			-160 dBm/Hz
50 MHz - 1 GHz			-165 dBm/Hz
1 GHz - 2 GHz			-166 dBm/Hz
2 GHz - 3 GHz			-164 dBm/Hz

Performance Verification

IF Flatness (Channel Response) Center frequency < 3 GHz	Low limit	Test Result	High limit
Span Setting			
300 kHz	-0.2 dB		+0.2 dB
10 MHz	-0.4 dB		+0.4 dB
20 MHz	-0.4 dB		+0.4 dB
40 MHz	-0.5 dB		+0.5 dB
110 MHz (Option 110 only)	-0.9 dB		+0.9 dB

Residual Response	Low limit	Test Result	High limit
200 MHz - 6.2 GHz			-95 dBm

Image Suppression	Low limit	Test Result	High limit
All Models			
1 GHz			-80 dBc
3.868 GHz			
RSA6114A only			
8.2 GHz			-76 dBc
9.1 GHz			
10 GHz			
11 GHz			
12 GHz			

Spurious Response with Signal	Low limit	Test Result	High limit
<1 MHz of Center Frequency	Fail		Pass
>1 MHz of Center Frequency	Fail		Pass
>1 MHz of Center Frequency (Option 110 only)	Fail		Pass

Spurious Response with Signal (Half IF)	Low limit	Test Result	High limit
9 kHz			-57 dBc
1 GHz			
2 GHz			
3 GHz			
4 GHz			
5 GHz			
6 GHz			
7 GHz (RSA6114A only)			
8 GHz (RSA6114A only)			

